

ICS 91.060.40

English version

## Chimneys - Requirements for metal chimneys - Part 1: System chimney products

Conduits de fumée - Prescriptions pour les conduits de fumée métalliques - Partie 1: Composants de systèmes de conduits de fumée

Abgasanlagen - Anforderungen an Metall-Abgasanlagen - Teil 1: Bauteile für System-Abgasanlagen

This European Standard was approved by CEN on 17 January 2003.

CEN members are bound to comply with the CEN/CENELEC Internal Regulations which stipulate the conditions for giving this European Standard the status of a national standard without any alteration. Up-to-date lists and bibliographical references concerning such national standards may be obtained on application to the Management Centre or to any CEN member.

This European Standard exists in three official versions (English, French, German). A version in any other language made by translation under the responsibility of a CEN member into its own language and notified to the Management Centre has the same status as the official versions.

CEN members are the national standards bodies of Austria, Belgium, Czech Republic, Denmark, Finland, France, Germany, Greece, Hungary, Iceland, Ireland, Italy, Luxembourg, Malta, Netherlands, Norway, Portugal, Slovakia, Spain, Sweden, Switzerland and United Kingdom.



EUROPEAN COMMITTEE FOR STANDARDIZATION  
COMITÉ EUROPÉEN DE NORMALISATION  
EUROPÄISCHES KOMITEE FÜR NORMUNG

Management Centre: rue de Stassart, 36 B-1050 Brussels

---

## Contents

	page
<b>Foreword</b> .....	<b>3</b>
<b>Introduction</b> .....	<b>4</b>
<b>1 Scope</b> .....	<b>4</b>
<b>2 Normative references</b> .....	<b>4</b>
<b>3 Terms and definitions</b> .....	<b>5</b>
<b>4 Manufacturer's declaration for type test</b> .....	<b>10</b>
<b>5 Dimensions and tolerances</b> .....	<b>11</b>
<b>6 Performance requirements</b> .....	<b>11</b>
6.1 Mechanical resistance and stability.....	11
6.2 Resistance to fire.....	12
6.3 Hygiene, health and environment. Gas tightness .....	12
6.4 Safety in use.....	13
6.5 Durability.....	15
<b>7 Product information</b> .....	<b>17</b>
7.1 Manufacturer's instructions .....	17
7.2 Minimum information to be included in the manufacturer's documentation and instructions .....	17
<b>8 Marking</b> .....	<b>18</b>
8.1 Chimney sections, fittings or terminals.....	18
8.2 Chimney plate .....	18
<b>9 Product designation</b> .....	<b>19</b>
<b>10 Evaluation of conformity</b> .....	<b>19</b>
10.1 General.....	19
10.2 Type testing .....	20
10.3 Factory production control (FPC) .....	20
<b>Annex A (normative) Corrosion tests</b> .....	<b>23</b>
<b>Annex B (normative) Choice of size for type test and sampling</b> .....	<b>43</b>
<b>Annex C (normative) Sampling for factory production control</b> .....	<b>44</b>
<b>Annex D (normative) Factory production control</b> .....	<b>47</b>
<b>Annex ZA (informative) Clauses of this European standard addressing the provisions of the EU Construction Products Directive</b> .....	<b>49</b>
<b>Bibliography</b> .....	<b>59</b>

## Foreword

This document (EN 1856-1:2003) has been prepared by Technical Committee CEN/TC 166, "Chimneys", the secretariat of which is held by UNI.

This European Standard shall be given the status of a national standard, either by publication of an identical text or by endorsement, at the latest by December 2003, and conflicting national standards shall be withdrawn at the latest by March 2005.

This document has been prepared under a mandate given to CEN by the European Commission and the European Free Trade Association, and supports essential requirements of EU Directive(s).

For relationship with EU Directive(s), see informative annex ZA, which is an integral part of this document.

Annexes A, B, C and D are normative.

According to the CEN/CENELEC Internal Regulations, the national standards organizations of the following countries are bound to implement this European Standard: Austria, Belgium, Czech Republic, Denmark, Finland, France, Germany, Greece, Hungary, Iceland, Ireland, Italy, Luxembourg, Malta, Netherlands, Norway, Portugal, Slovakia, Spain, Sweden, Switzerland and the United Kingdom.

## **Introduction**

This European Standard has been prepared to be a harmonised standard to provide means of conforming to the essential requirements of the Construction Products Directive and associated EFTA regulations.

The generic word "chimney", when used in this standard, refers to systems with metallic liner used to convey the products of combustion from any appliance to the outside atmosphere, and thus includes all other terms of common use in the trade, such as: vents, flues, shafts, exhaust systems, ducts, etc.

This standard addresses the durability against corrosion by the use of a minimum material specification for the flue liner as well as an interim solution for testing products for durability against corrosion. Three corrosion resistance tests and their requirements have been adopted from existing corrosion testing being undertaken in various member states (see annex A).

Is intended to review the interim solution within a period of 5 years with the intention to develop a unique test method for durability against corrosion as a final solution.

This standard describes chimney components, from which system chimneys can be assembled as illustrated in Figure 1.

## **1 Scope**

This standard specifies the performance requirements for single- and multi-wall system chimney products with metallic liners (chimney sections, chimney fittings and terminals, including supports) used to convey the products of combustion from appliances to the outside atmosphere. It also specifies the requirements for marking, manufacturer's instructions, product information and evaluation of conformity. Metal liners and metal connecting flue pipes not covered here, are included in prEN 1856-2:1996.

This standard does not apply to structurally independent (free standing or self-supporting) chimneys.

## **2 Normative references**

This European Standard incorporates by dated or undated reference, provisions from other publications. These normative references are cited at the appropriate places in the text, and the publications are listed hereafter. For dated references, subsequent amendments to or revisions of any of these publications apply to this European Standard only when incorporated in it by amendment or revision. For undated references the latest edition of the publication referred to applies (including amendments).

EN 573-3	<i>Aluminium and aluminium alloys - Chemical composition and form of wrought products - Part 3: Chemical composition.</i>
EN 1443:2003	<i>Chimneys - General requirements.</i>
EN 1859:2000	<i>Chimneys - Metal chimneys - Test methods.</i>
EN 10088-1	<i>Stainless steel - Part 1: List of stainless steels.</i>
prEN 12391	<i>Chimneys - Metal chimneys.</i>
EN 13384-1:2002	<i>Chimneys - Thermal and fluid dynamic calculation methods - Part 1: Chimneys serving one appliance.</i>
EN ISO 3651-2	<i>Determination of resistance to intergranular corrosion of stainless steels. Part 2: Ferritic, austenitic and ferritic-austenitic (duplex) stainless steels. Corrosion test in media containing sulfuric acid (ISO 3651-2:1998).</i>

### 3 Terms and definitions

For the purposes of this European Standard, the following terms and definitions apply:

#### 3.1

##### **appliance outlet**

position where the products of combustion exit from the appliance (see Figure 1)

#### 3.2

##### **chimney**

structure consisting of a wall or walls enclosing a flue or flues

[EN 1443:2003]

#### 3.3

##### **chimney accessory**

chimney component not conveying products of combustion

[EN 1443:2003]

#### 3.4

##### **chimney component**

any part of a chimney

[EN 1443:2003]

#### 3.5

##### **chimney designation**

shortened description of a specific chimney type, which clearly distinguishes it from any other types

#### 3.6

##### **chimney fitting**

chimney component conveying products of combustion except a chimney section (see Figure 1)

[EN 1443:2003]

#### 3.7

##### **chimney section**

straight chimney component conveying products of combustion (see Figure 1)

[EN 1443:2003]

#### 3.8

##### **cladding**

additional non-structural outer wall around a chimney for protection against heat transfer or weathering, or for decorative purposes (see Figure 1)

[EN 1443:2003]

#### 3.9

##### **connecting flue pipe**

component or components connecting the heating appliance outlet and the chimney (see Figure 1)

[EN 1443:2003]

## **EN 1856-1:2003 (E)**

### **3.10**

#### **corrosion load**

combination of condensate and corrosion resistance classes necessary for the different operating conditions and types of fuel

### **3.11**

#### **custom built chimney**

chimney that is installed or built on-site using a combination of compatible chimney components that may be from one or different sources

[EN 1443:2003]

### **3.12**

#### **design load (DL)**

load which a chimney or its components are designed to be subjected to, under normal operating conditions, when installed as per manufacturer's installation instruction

### **3.13**

#### **dry operating condition**

condition when a chimney is designed to operate normally with the temperature of the inner surface of the flue liner above the water dew point

[EN 1443:2003]

### **3.14**

#### **enclosure**

barrier that, when built around a chimney, will give additional safety in case of fire and can provide additional heat transfer resistance (see Figure 1)

[EN 1443:2003]

### **3.15**

#### **external installation**

part of a chimney, which is located outside the building

### **3.16**

#### **flexible pipe**

metal liner, or metal connecting flue pipe having a single or double skin construction, designed to bend in any direction without permanent deformation

### **3.17**

#### **flue**

passage for conveying the products of combustion to the outside atmosphere (see Figure 1)

[EN 1443:2003]

### **3.18**

#### **flue gas**

gaseous portion of the products of combustion conveyed in a flue

[EN 1443:2003]

### **3.19**

#### **flue liner**

wall of a chimney consisting of components the surface of which is in contact with products of combustion (see Figure 1)

[EN 1443:2003]

**3.20**

**heating appliances**

unit generating products of combustion which need to be conveyed to the outside atmosphere (see Figure 1)

[EN 1443:2003]

**3.21**

**insulation**

material or air gap between the flue liner and the outer wall, designed to increase thermal resistance of the chimney (see Figure 1)

**3.22**

**internal installation**

part of a chimney, which is located inside a building

**3.23**

**joint**

connection between two components (see Figure 1)

[EN 1443:2003]

**3.24**

**manufacturer instructions**

product written information which is provided for use by the buyer or installer

**3.25**

**metal chimney**

chimney with its flue liner made of metal, which may have additional surrounding structural elements and accessories, as well as insulation

**3.26**

**metal liner**

rigid or flexible flue liner made of metal

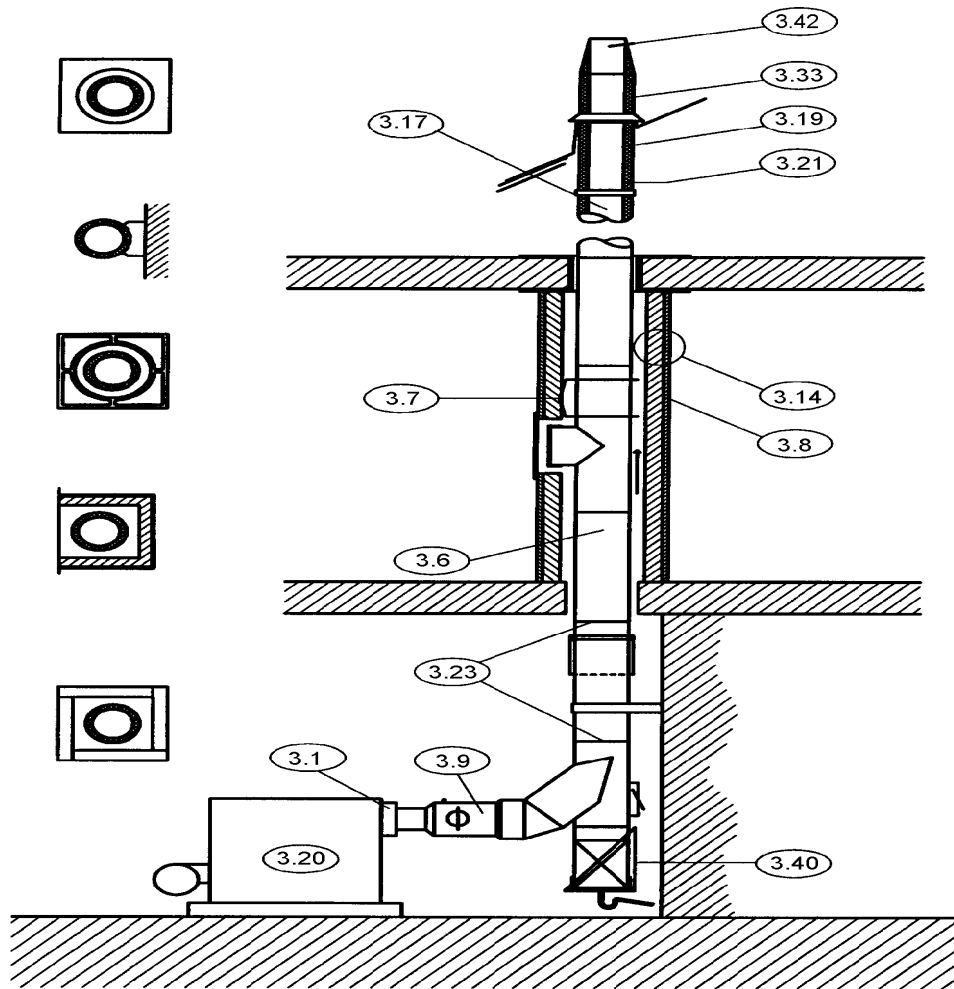

Figure 1 — Terminology. chimney components and chimney accessories

**3.27**

**minimum declared wall thickness**

value for the minimum thickness of the liner wall as stated by the manufacturer for the type test

**3.28**

**multi-wall chimney**

chimney consisting of a flue liner and at least one additional wall

[EN 1443:2003]

**3.29**

**multi-wall metal chimney**

chimney of two walls or more, all made of metal

**3.30**

**negative pressure chimney**

chimney designed to operate with the pressure inside the flue less than the pressure outside the flue

[EN 1443:2003]

**3.31**

**nominal size**

whole number representing the value of the internal diameter of the flue liner, expressed in millimetres

**3.32****non enclosed chimney**

chimney which is installed without any enclosure or cladding

**3.33****outer wall**

external wall of a chimney, the surface of which comes in contact with ambient or the external environment, or is within cladding or enclosure (see Figure 1)

[EN 1443:2003]

**3.34****positive pressure chimney**

chimney designed to operate with the pressure inside the flue greater than the pressure outside the flue

[EN 1443:2003]

**3.35****relining**

process of restoring or replacing the flue liner of a chimney

[EN 1443:2003]

**3.36****resistance to fire**

the ability of a chimney to prevent ignition of adjacent combustible material, and to prevent the spread of fire to adjacent areas

**3.37****single-wall chimney**

chimney where the flue liner is the chimney

[EN 1443:2003]

**3.38****sootfire**

combustion of the flammable residue deposited on the flue liner

[EN 1443:2003]

**3.39****structurally independent chimney**

chimney which is not attached to buildings, masts or other support structure

**3.40****support**

chimney accessory used to fix, or transfer the load of, chimney components to structural elements (building, mast, etc.) (see Figure 1)

**3.41****system chimney**

chimney that is installed using a combination of compatible chimney components, obtained or specified from one manufacturing source with product responsibility for the whole chimney

[EN 1443:2003]

**3.42****terminal**

fitting installed at the outlet of a chimney (see Figure 1)

## **EN 1856-1:2003 (E)**

[EN 1443:2003]

### **3.43**

#### **test assembly**

complete assembly of all parts necessary to enable the specific performance criteria to be assessed, comprising test chimney, test structures, and measuring equipment (as specified in the test method)

### **3.44**

#### **test chimney**

assembly of the chimney components (as specified in the test method), necessary to the assessment of a specific performance criteria of a metal system chimney product

### **3.45**

#### **test structure**

assembly of the additional materials (non-chimney components) to enable the test chimney to be assessed for the specific performance criteria

### **3.46**

#### **thermal resistance of a chimney**

resistance to heat transfer through the wall or walls of the chimney

[EN 1443:2003]

### **3.47**

#### **wet operating condition**

condition when the chimney is designed to operate normally with the temperature of the inner surface of the flue liner at or below the water dew point

[EN 1443:2003]

## **4 Manufacturer's declaration for type test**

The manufacturer shall provide the relevant information from 7.2 and, in addition, shall declare:

- a) the type of metals from which the chimney fittings or sections are made, according to EN 10088-1 and EN 573-3, and the nominal and minimum wall thickness;
- b) the internal diameter of the chimney fittings or sections and the nominal product size;
- c) the minimum wall thickness after manufacture, the installed length, liner external circumference, total mass and design loads of the fitting or section and, if appropriate, the insulation density or mass.

## 5 Dimensions and tolerances

5.1 The thickness of the material from which the components are made shall be not less than the minimum wall thickness according to 4 a).

5.2 The declared internal diameter of the fitting or section shall be not less than  $\pm 5$  mm from the nominal size. The measured internal diameter of the fitting or section shall not be less than the diameter declared by the manufacturer [see 4 b)].

5.3 The external circumference of the liner of the fitting or section shall be within  $\begin{matrix} +5 \\ 0 \end{matrix}$  mm up to 600 mm internal diameter and within  $\begin{matrix} +13 \\ 0 \end{matrix}$  mm over 600 mm internal diameter, of that declared by the manufacturer [see 4 c)].

5.4 The installed length of a fitting or section (measured on an assembly including at least one joint) shall be within  $\pm 5$  mm of that declared by the manufacturer [see 4 c)].

5.5 The density of insulation in a fitting or a section shall be within  $\begin{matrix} +30 \\ 0 \end{matrix}$  % of that declared by the manufacturer [see 4 c)].

## 6 Performance requirements

Unless otherwise stated, performance requirements for fittings shall be the same as those for chimney sections.

### 6.1 Mechanical resistance and stability

#### 6.1.1 Compressive strength

##### 6.1.1.1 Chimney sections and fittings

The manufacturer shall declare the relevant design loads.

When tested according to the test method described in EN 1859 a multi-wall chimney section or fitting shall withstand a load of at least three times the manufacturer's declared design load.

When tested according to the test method described in EN 1859, single- and multi-wall chimney sections or fittings where the flue liner is load bearing, shall withstand a load of at least four times the manufacturer's declared design load.

##### 6.1.1.2 Chimney support

The manufacturer shall declare the relevant design loads.

When tested according to the test method described in EN 1859, the maximum displacement of the test chimney at the support shall not be greater than 5 mm, in the direction of the load when the manufacturer's declared design load is applied.

The support shall withstand an intensity of loading of at least three times the manufacturer's declared design load.

#### 6.1.2 Tensile strength

The manufacturer shall declare the relevant design loads.

When a chimney section is tested according to the test method of EN 1859, the chimney section shall withstand a load of at least 1,5 x the manufacturer's declared design load.

### 6.1.3 Lateral strength

#### 6.1.3.1 Non-vertical installation

When a chimney section, declared by the manufacturer as suitable for non-vertical installation, is tested according to the test method described in EN 1859, the deflection of any part of the test chimney shall not be more than 2 mm/m in distance between supports.

#### 6.1.3.2 Components subject to wind load

When chimney components declared by the manufacturer as suitable for external installation are tested according to the test method of EN 1859, the test chimney shall withstand a minimum load of 1,5 kN/m<sup>2</sup> of projected outer surface area.

## 6.2 Resistance to fire

The manufacturer shall declare the minimum distance to combustible material and the requirements of 6.4.1 shall be met.

### 6.2.1 Sootfire resistance

When a chimney made of sections and/or fittings designated as sootfire resistant is tested according to the thermal shock test method described in EN 1859, the maximum surface temperature of combustible materials adjacent to the test chimney, at the distance declared, shall not exceed 100°C when related to an ambient temperature of 20°C and shall meet the gas tightness given in 6.3.

The distance declared shall not exceed the criteria for normal operating conditions.

## 6.3 Hygiene, health and environment. Gas tightness

When a chimney is tested according to the test methods described in EN 1859, the leakage rate shall not be greater than that given in Table 1, both before and after the thermal performance test at normal operating condition and, where appropriate, the resistance to sootfire test (see annex I of EN 1859:2000).

Table 1 — Leakage rate

Pressure type	Test pressure Pa	Leakage rate/Flue surface area $l \cdot s^{-1} \cdot m^{-2}$
N1	40	< 2,0
P1	200	< 0,006
P2	200	< 0,120
H1	200 and 5 000	< 0,006
H2	200 and 5 000	< 0,120

## 6.4 Safety in use

### 6.4.1 Thermal performance at normal operating conditions

When a chimney made of sections and/or fittings is tested according to the heat stress test method described in EN 1859, the maximum surface temperature of combustible materials adjacent to the test chimney, at the distance declared, for the nominal working temperature, shall not be greater than 85°C, when related to an ambient temperature of 20°C and shall meet the gas tightness given in 6.3.

### 6.4.2 Accidental human contact

Where accidental human contact of a chimney is possible the outer wall surface temperature of the chimney shall not be greater than the appropriate value given in Table 2.

**Table 2 — Maximum outer wall surface temperatures**

Material of outer wall surface	Maximum allowed temperature °C
Metal-bare	70
Metal-painted	80
Metal-enamelled	86
Metal-plastic covered	90
NOTE The values in Table 2 are based on the criteria in EN 563 relating to a 1 s burn threshold.	

**6.4.3 Thermal resistance**

The thermal resistance value of the chimney section declared by the manufacturer shall be verified either by testing, according to the test method of EN 1859, or by calculation using either the simplified calculation or the finite difference equation of annexes F and G of EN 1859:2000.

When the value for the thermal resistance is calculated, the thermal conductivity value shall be based on the mean temperature of the insulation depending on the nominal temperature of Table 3.

**Table 3 — Temperature levels and test temperatures**

Temperature level	Nominal working temperature (T) °C	Flue gas test temperature °C
T 080	≤ 80	100
T 100	≤ 100	120
T 120	≤ 120	150
T 140	≤ 140	170
T 160	≤ 160	190
T 200	≤ 200	250
T 250	≤ 250	300
T 300	≤ 300	350
T 400	≤ 400	500
T 450	≤ 450	550
T 600	≤ 600	700

**6.4.4 Water vapour diffusion resistance**

When a section or fitting designated for wet operating conditions is tested according to the test method described in EN 1859, the outer surface of the section or fitting shall remain dry and the increase in mass of the section or fitting shall not exceed 1,0 % of the insulating material.

**6.4.5 Condensate penetration resistance**

When a section or fitting designated for wet operating conditions is tested according to the test method described in EN 1859, the outer surface of the section or fitting shall remain dry and the increase in mass of the section or fitting shall not exceed 1,0 % of the insulating material.

**6.4.6 Rainwater penetration resistance**

When a section or fitting designated for external installation is tested according to the test method described in EN 1859, the increase in mass of the section or fitting shall not exceed 1,0% of the insulating material.

## 6.4.7 Flow resistance

### 6.4.7.1 Chimney sections

The manufacturer shall declare the mean value of roughness for chimney sections, which shall be determined according to the method given in subclause 4.12 of EN 1859:2000 or obtained from data given in EN 13384-1:2002.

### 6.4.7.2 Chimney fittings

The manufacturer shall declare the coefficient of flow resistance due to a directional and/or cross-sectional and/or mass flow change in the flue for chimney fittings which shall be determined according to the method given in subclause 4.12 of EN 1859:2000 or obtained from data given in EN 13384-1:2002.

### 6.4.7.3 Terminals

The manufacturer shall declare the coefficient of flow resistance of the terminal which shall be verified according to the test method described in subclause 4.10 of EN 1859:2000 .

## 6.4.8 Other requirements for terminals

### 6.4.8.1 Rain protection terminals

Where a rain protection terminal is tested for rain water penetration according to the test method described in EN 1859, the mass of the water collected in the flue liner shall not exceed  $5 \times 10^{-2} \text{ mm}^3/\text{s}$  per millimetre of flue liner diameter.

### 6.4.8.2 Aerodynamic behaviour

When a terminal is tested according to the test method described in EN 1859 the static pressure in the terminal  $P_{static}$  shall meet the following formula:

$$P_{static} \leq \Delta P_R - 0,2 \cdot W_L^2$$

where

- $\Delta P_R$  is the pressure difference, in Pa, as declared by the manufacturer, between the flue liner and the test room at the internal flow velocity of 1 m/s;
- $W_L$  is the wind speed, in m/s.

For negative pressure chimneys the value  $\Delta P_R$  shall be 2 Pa maximum.

For positive pressure chimneys the value  $\Delta P_R$  is the actual value that is measured under the conditions given in subclause 6.4.7.3, by the flow velocity of 2 m/s.

## 6.5 Durability

### 6.5.1 Durability of the flue liner against corrosion

Durability against corrosion shall be declared either on the basis of:

- a) material type (according to Table 4) and thickness of the flue liner; or
- b) on the basis of the results of at least one of the three test methods described in normative annex A.

Products which have a declaration on the basis of material type and thickness shall be designated Vm.

Products passing the test described in clause A.1 shall be designated V1.

## EN 1856-1:2003 (E)

Products passing the test described in clause A.2 shall be designated V2.

Products passing the test described in clause A.3 shall be designated V3.

The product designation shall, in any case, include the flue liner material specification, according to 6.5.2.

NOTE The link between Vm, V1, V2 and V3 and the allowed use is dependent on individual member states regulations where they exist.

### 6.5.2 Flue liner material specification

The complete material specification of the flue liner shall be formed by the letter L followed by five digits. The first two digits shall represent the material type as in Table 4 and the last three digits shall represent the material thickness in multiples of the unit 0,01 mm.

#### EXAMPLE

L40045 represents a liner made of 1.4401 stainless steel with a thickness of 0,45 mm.

**Table 4 — Flue liner material specification (according to EN 10088-1 and EN 573-3)**

Material type	Material N°	Symbol
10	EN AW – 4047A	EN AW Al Si 12(A) and CU <0,1%, Zn<0,15% (cast aluminium)
11	EN AW – 1200A	EN AW-AL 99,0 (A)
13	EN AW-6060	EN AW-Al MgSi
20	1.4301	X5CrNi 18-10
30	1.4307	X2CrNi 18-9
40	1.4401	X5CrNiMo 17-12-2
50	1.4404 <sup>a</sup>	X2CrNiMo 17-12-2
60	1.4432	X2CrNiMo 17-12-3
70	1.4539	X1NiCrMoCu 25-20-5

<sup>a</sup> Equivalent for material N° 1.4404 = 1.4571(symbol X6CrNiMoTi 17-12-2).

### 6.5.3 Freeze-thaw resistance

Metal chimney products are considered deemed to satisfy free freeze-thaw resistance.

## 7 Product information

### 7.1 Manufacturer's instructions

The manufacturer's instructions shall be available in the language of each country in which the product is sold.

### 7.2 Minimum information to be included in the manufacturer's documentation and instructions

The manufacturer shall include in his documentation and instructions the following minimum information:

- manufacturer identification;
- product designation in accordance with clause 9 and its explanation;
- material specification;
- wind load resistance
  - limitations of height location of exposed section of the chimney,
  - maximum distances between lateral supports or guides;
- compressive strength
  - maximum load,
  - mass and dimensions of chimney components;
- minimum distance to combustible materials;
- flow resistance factors of fittings and chimney sections;
- thermal resistance in  $\text{m}^2 \text{K/W}$ ;
- flexural strength
  - maximum offset,
  - maximum suspended load from the sections and fittings;
- dangerous substances;
- installation drawing typical of the application;
- method of jointing the components;
- method of installing sections or fittings, supports and accessories including weatherproofing;
- instruction on how to complete the data of the chimney plate according to prEN 12391.

And where appropriate:

- direction of flow;
- storage instructions;

## **EN 1856-1:2003 (E)**

- method of application of any sealant required;
- individual assembly instructions for any components which are supplied in unassembled conditions;
- minimum distance from chimney outer surface to the inner surface of the enclosure;
- positions of apertures for cleaning and inspection;
- installation of chimney plate to the chimney, cladding or enclosure;
- terminal aerodynamic properties, including pressure drop in no wind condition;
- need for human contact shielding (based on outer surface temperature test results);
- enclosure/cladding/specification/limitation;
- other material specifications (e.g. seals);
- specific methods or instruments for cleaning;

NOTE 1 The normal method of cleaning is by the use of a brush which should not be made of black steel.

- recommendations on condensate drainage.

NOTE 2 The product information required in this clause must not be confused with those relevant for CE marking (see clause ZA.3 of annex ZA for this purpose).

## **8 Marking**

NOTE For CE marking and labelling purposes the provisions of clause ZA.3 of annex ZA apply.

### **8.1 Chimney sections, fittings or terminals**

Chimney sections, fittings or terminals shall be marked with the following information:

- a) product designation in accordance with clause 9;
- b) name or trademark of the manufacturer;
- c) manufacturing batch or product reference of manufacturer;
- d) arrow indicating direction of flue gases (if applicable).

### **8.2 Chimney plate**

The manufacturer shall make available a chimney plate made of a durable material which shall include the following information:

- a) name or trademark of the manufacturer, engraved or indelibly marked;
- b) space for designation in accordance with EN 1443;
- c) space for nominal size;
- d) space for minimum distance to combustible material, indicated in millimetres, followed by the symbol of an arrow and a flame;
- e) space for installer data and date of installation.

### 8.2.1 Packaging

Each package within a consignment shall be legibly marked with the following information:

- a) product designation, in accordance with clause 9;
- b) name or trademark of the manufacturer;
- c) nominal size.

## 9 Product designation

All chimney sections and fittings shall be designated in accordance with the following designation system:

Example:

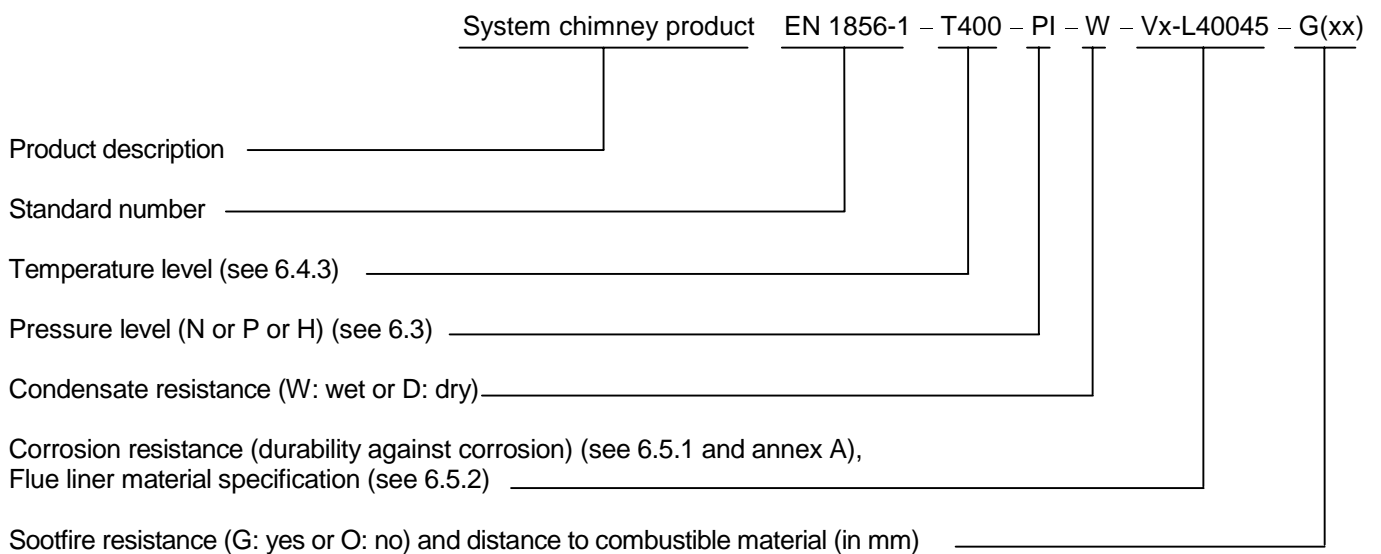

## 10 Evaluation of conformity

### 10.1 General

The compliance of a system chimney product with the requirements of this standard and with the stated values (including classes) shall be demonstrated by:

- initial type testing;
- factory production control by the manufacturer, including product assessment.

## EN 1856-1:2003 (E)

### 10.2 Type testing

#### 10.2.1 Initial type testing

Initial type testing shall be performed to show conformity with this standard. Tests previously performed in accordance with the provisions of this standard [same product, same characteristic(s), test method, sampling procedure, system of attestation of conformity, etc.] may be taken into account. In addition, initial type testing shall be performed at the beginning of the production of a new system chimney product or at the beginning of a new method of production (where this may affect the stated properties).

Where characteristics are determined on the basis of conformity with other product standards (for insulation material, metals including coatings, seals and sealants), these characteristics do need not be reassessed provided that the designer ensures the validity of the results. Products CE marked in accordance with appropriate harmonised European specifications may be presumed to have the performances stated of them, although this does not replace the responsibility of the manufacturer to ensure that the system chimney product as a whole is correctly designed and its component products have the necessary performance values.

All characteristics defined in clauses 5 and 6 shall be subject to initial type testing, with the following exception:

- release of dangerous substances which may be assessed indirectly by controlling the content of the substance concerned.

#### 10.2.2 Further type testing

Whenever a change occurs in the system chimney product design, the raw material or supplier of the components, or the production process, which would change the tolerances or requirements of clauses 5 and 6 for one or more of the characteristics, the type tests shall be repeated for the appropriate characteristic(s).

#### 10.2.3 Sampling for type testing

The size of products to be tested shall be according to annex B.

The number of system chimney products to be tested for any one size shall be in accordance with the requirements of the relevant clauses of EN 1859.

The results of all type tests shall be recorded and held by the manufacturer, until superseded.

### 10.3 Factory production control (FPC)

#### 10.3.1 General

NOTE A FPC system conforming with the following requirements of the relevant part(s) or EN ISO 9001:2000, and made specific to the requirements of this standard, is considered to satisfy the above requirements.

The manufacturer shall establish, document and maintain a FPC system to ensure that the manufactured products conform to the stated performance characteristics. The FPC system shall consist of procedures, regular inspections and tests and/or assessments and the use of the results to e.g. control raw and other incoming materials or components, equipment, the production process and the product.

The manufacturer is responsible for organising the effective implementation of the factory production control system. Tasks and responsibilities in the production control organisation should be documented and this documentation should be kept up-to-date. In each factory the manufacturer may delegate the action to a person having the necessary authority to:

- identify procedures to demonstrate conformity of the product at appropriate stages;
- identify and record any instance of non-conformity;
- identify procedures to correct instances of non-conformity.

The manufacturer should draw up and keep up-to-date documents defining the factory production control which he applies. The manufacturer's documentation and procedures should be appropriate to the product and manufacturing

process. All FPC systems should achieve an appropriate level of confidence in the conformity of the product. This involves:

- a) the preparation of documented procedures and instructions relating to factory production control operations, in accordance with the requirements of the reference technical specification;
- b) the effective implementation of these procedures and instructions;
- c) the recording of these operations and their results;
- d) the use of these results to correct any deviations, repair the effects of such deviations, treat any resulting instances of non-conformity and, if necessary, revise the FPC to rectify the cause of non-conformity.

The production control operations shall include some or all of the following operations:

- a) the specification and verification of raw materials and constituents;
- b) the controls and tests to be carried out during manufacture according to a frequency laid down;
- c) the verifications and tests to be carried out on finished products according to a frequency which may be laid down in the technical specifications and adapted to the product and its conditions of manufacture.

NOTE Depending on the specific case, it may be necessary to carry out i) the operations referred to under b) and c), ii) only the operations under b) or iii) only those under c).

## **EN 1856-1:2003 (E)**

The operations under b) center as much on the intermediate states of the product as on manufacturing machines and their adjustment, and equipment, etc. These controls and tests and their frequency are chosen based on product type and composition, the manufacturing process and its complexity, the sensitivity of product features to variations in manufacturing parameters, etc.

The manufacturer shall have or have available the installations, equipment and personnel which enable him to carry out the necessary verifications and tests. He may, as may his agent, meet this requirement by concluding a sub-contracting agreement with one or more organizations or persons having the necessary skills and equipment.

The manufacturer has responsibility to calibrate or verify and maintain the control, measuring or test equipment in good operating condition, whether or not it belongs to him, with a view to demonstrating conformity of the product with its technical specification. The equipment shall be used in conformity with the specification or the test reference system to which the specification refers.

If necessary, monitoring is carried out of the conformity of intermediate states of the product and at the main stages of its production.

This monitoring of conformity focuses where necessary on the product throughout the process of manufacture, so that only products having passed the scheduled intermediate controls and tests are dispatched.

The results of inspections, tests or assessments requiring action shall be recorded, as any action taken. The action to be taken when control values or criteria are not met shall be recorded.

### **10.3.2 Equipment**

All weighing, measuring and testing equipment shall be calibrated and regularly inspected according to documented procedures, frequencies and criteria.

### **10.3.3 Raw materials and components**

The specifications of all incoming raw materials and components shall be documented, as the inspection scheme for ensuring their conformity.

### **10.3.4 Product testing and evaluation**

The manufacturer shall establish procedures to ensure that the stated values of the characteristics are maintained. Sampling for FPC shall be according to annex C. The characteristics are given in annex D.

### **10.3.5 Non conforming products**

Non conforming products shall be handled according to annex C.

## Annex A (normative)

### Corrosion tests

#### A.1 Corrosion test method for products designated V1

##### A.1.1 General

This test protocol specifies the corrosion resistance test for the flue liners of both single- and multi-wall metal chimneys conveying products of combustion from appliance to outside atmosphere.

It specifies the test conditions for the chimney products designated V1.

##### A.1.2 Pass/Fail criteria

In order to pass the test method described in A.1.4, no perforation of the wall of the flue liner shall occur.

##### A.1.3 Sampling

Unless otherwise stated, the requirements of annex B shall apply.

##### A.1.4 Test methods

###### A.1.4.1 Introduction

The chimney corrosion test consists of exposing a test assembly to specified test conditions and evaluating the effects. The test conditions can be separated into flow conditions, flue gas spiking levels and ambient conditions.

To register and control the test conditions, the test assembly is connected to the test equipment. The test equipment consists of a flue gas generator, a connecting piece and instrumentation.

All physical values are specified as measured. All accuracy is specified as  $1\sigma^1$ .

###### A.1.4.2 The test conditions

###### A.1.4.2.1 Flow conditions

The flow conditions shall be applied during a testing period of 4 weeks.

The flow conditions are cycled during the testing period.

A single cycle (see Figure A.1) consists of four phases:

Phase 1: 5 min with flue gas temperature of 85 °C for condensate resistance group W, and 120 °C for condensate resistance group D.

Phase 2: Cooling phase as phase 4.

Phase 3: 5 min with flue gas temperature of the intended nominal temperature.

---

<sup>1)</sup>  $\sigma$  = Standard deviation.

## EN 1856-1:2003 (E)

Phase 4: Cooling phase of 5 min to reach a surface temperature of lower than 45 °C at the end of the test assembly (50 cm below the outlet). If necessary, with ventilation with air to reach a surface temperature of lower than 45 °C.

The total amount of cycles is 2 016 (based on a testing period of 4 weeks).

The velocity of the flue gas in the test assembly shall be 1 m/s  $\pm$  0,1 m/s for negative pressure liners and 3 m/s  $\pm$  0,3 m/s for positive pressure liners at the intended test temperature and at the intended flue gas water vapour content.

The intended test temperature is the nominal working temperature of the chimney as declared by its nominal temperature class or 200 °C, whichever is lower.

The water vapour content of the flue gas is equal to the water vapour content of flue gases of the intended fuel (natural gas for V1) using an air ratio of 1.2. The values to be realised are shown in Table A.1.

**Table A.1 — Water vapour content of flue gas used during exposure**

Chimney Designation	Flue gas water vapour content [vol%]
V1	17 $\pm$ 0,5

The air ratio and consequently the CO<sub>2</sub>-content of the flue gases in the test assembly shall be adjusted to a level ensuring the correct level of water vapour content (see Table A.1 and Table A.2).

**Table A.2 — CO<sub>2</sub>-content of flue gas used during exposure (informative)**

Chimney Designation	Flue gas CO <sub>2</sub> content [vol%, dry]
V1	10 $\pm$ 0,5

For the test of positive pressure chimneys a flue gas pressure of 100 Pa  $\pm$  10 Pa shall be maintained in the test assembly by using a restriction at the outlet. The pressure is measured at a location 2d before the restriction at the end of phase 3.

For the test of negative pressure chimneys the test assembly shall be free of restrictions.

### A.1.4.2.2 Spiking levels

The concentration levels of sulphur dioxide and chlorides at the outlet of the combustor shall be as specified in Table A.3.

**Table A.3 — Concentration levels for the different corrosion resistance classes**

Corrosion resistance group	Sulfur dioxide concentration	Chloride concentration
V1	10 mg/m <sup>3</sup> $\pm$ 10%	4 mg/m <sup>3</sup> $\pm$ 10%
V1	10 mg/m <sup>3</sup> $\pm$ 10%	4 mg/m <sup>3</sup> $\pm$ 10%

Fuel spiking with special chemicals shall be carried out to achieve these concentration levels. The organic sulphur compound tetrathiothiophene ( $\text{CH}_2$ )<sub>4</sub>S (THT) is selected, as it is a liquid used as odorant for natural gas. Complete combustion of THT takes place in the burner flame producing a defined amount of sulphur dioxide ( $\text{SO}_2$ ).

As organic chlorine compound 1,2,3-trichloropropane ( $\text{C}_3\text{H}_5\text{Cl}_3$ ) is selected, because it is a liquid with a relatively low toxicity and high boiling point. Complete combustion takes place in the burner flame producing a defined amount of hydrochloric acid (HCl).

#### A.1.4.2.3 Ambient conditions

A supply of clean outdoor air for combustion shall be provided. Care shall be taken to avoid contamination from refrigerant gases, chlorine, cleaning solvents, welding fumes, etc. (e.g. by filtering the air).

When using liquid fuel the water content of the combustion air may be increased to achieve the necessary water content of the flue gas.

In the phases 2 and 4 of the corrosion cycle, the test chimney shall be ventilated. The temperature of the ventilation air shall be  $20\text{ °C} \pm 5\text{ °C}$ . The dew point of the ventilation air has to be  $12\text{ °C} \pm 3\text{ °C}$  for at least 90% of the test period. The ventilation air is taken out of the test room.

The test room temperature shall be  $20\text{ °C} \pm 5\text{ °C}$ .

In a circle of 2 m around the test assembly the maximum draught shall be below 0,5 m/s. These conditions shall be fulfilled for at least 90% of the test period<sup>1)</sup>.

#### A.1.4.3 Test assembly

The test assembly (see Figure A.2) shall have a minimum height of 3,5 m above flue gas entry and, if appropriate, shall include a lateral section of at least 0,5 m connected to the two vertical sections by two elbows. The inclination of the lateral section shall be at least 5 mm/m length or more, according to the manufacturer's installation instructions, so as to allow the condensate to flow back. If the system includes a T-piece, this shall be used to make the connection to the connecting piece. The nominal diameter of the test assembly shall be the smallest diameter of any product designation range.

In the case of testing chimneys with soot fire resistance designation the soot fire resistance test shall be done with the test assembly before the corrosion test.

The cooling of the test assembly shall be done by forced air ventilation.

#### A.1.4.4 Flue gas generator

The flue gas generator (see Figure A.3) is composed of three components, the combustor, the cooler and the connector (including a defined connecting piece).

The cooler shall be installed in such a way that no condensate flows back to the combustor.

The connecting piece between the cooler and the test assembly shall be insulated to provide a thermal resistance value not less than  $0,22\text{ m}^2\text{K/W}$ . Its exit shall have the same diameter,  $d$ , as the test assembly and a straight length of  $5d$ .

The combustor, the cooler and the connector shall be made of stainless steel with molybdenum content of at least 2%.

The cooler shall have an adjustable output with the necessary range between  $85\text{ °C}$  and the nominal temperature of the flue liner (up to a maximum temperature of  $200\text{ °C}$ ) with an accuracy of  $\pm 5\%$ . No condensation of water shall occur within the cooler.

---

<sup>1)</sup> This condition is assumed to be fulfilled without draught measurement if appropriate tight screening is placed around the test assembly. The distance from the test assembly to the screening must so large that the temperature of the screening is less than 2 K above test room temperature, but not more than 1 m.

#### A.1.4.5 Spiking system

The operation principle of the spiking system illustrated in Figure A.4 is based on the addition of a vaporous pollutant into a by-pass gas flow, which is connected to the main gas flow. To make sure that the vaporous pollutant is added proportionally, the by-pass gas flow rate is controlled by the main gas flow rate. The overall flow rate necessary to achieve the flue gas velocity required according to A.1.4.2.1 depends on the cross-section of the flue liner being tested.

The spiking system reduces the gas pressure in two steps from 1 bar to 25 mbar. The intermediate pressure is 150 mbar.

To allow the gas flow to be controlled, a mass flow meter (F) shall be installed in the main gas flow after the first reducer. This meter measures the flow rate of the main gas flow at a pressure of 150 mbar. By means of a converter (X) the measuring signal is transformed into a control signal, which is proportional to the measured main flow rate. This control signal is sent to a mass flow meter/controller (F, C) installed in the by-pass line. This unit controls the quantity of gas, which is passed through the liquid pollutant. The wash bottle containing the pollutant is kept at a constant temperature in a cryostat/thermostat bath (T, C). This constant temperature will cause the vapour pressure of pollutant to be also constant. By passing a part of the natural gas through the pollutant liquid R will be possible to ensure always a proper mixing of natural gas and pollutant vapour. Together with the natural gas the vaporous pollutant re-enters the by-pass line from the wash bottle. In the 25 mbar section this by-pass line is connected to the main flow as a result of which the natural gas and the high pollutant content natural gas from the by-pass are mixed.

The total sulphur and chlorine content of the final natural gas flow is a function of the gas flow rate and the temperature in the wash bottle. It is possible to change the pollutant content of the natural gas by changing the adjustment of the converter or by changing the temperature of the cryostat/thermostat bath. If the temperature in the cryostat/thermostat bath is higher than room temperature the line to the main gas flow shall be insulated to avoid condensation of pollutant on the wall of the connecting line.

The injection shall be done at least 1 m before the combustor.

#### A.1.4.6 Controls

During the whole test period the following parameters shall be recorded and adjusted when necessary:

— the fuel input flow with an accuracy  $\pm 5\%$ .

During the whole test period the following parameters shall be recorded:

— the inner wall temperature at the end of the test assembly (50 cm below the outlet) with an accuracy of  $5\text{ K}^1$ ;

— the temperature of the flue gas at the entrance of the test assembly with an accuracy of  $10\text{ K}^2$ ;

— the number of test cycles;

— the test room temperature near the test assembly with an accuracy of  $1\text{ K}$ ;

— the temperature of the ventilation air with an accuracy of  $1\text{ K}$  (might be the same temperature sensor when the ventilation air is taken from the immediate surroundings of the test assembly);

---

<sup>1)</sup> For the temperature measurements NiCr-Ni thermocouples may be used. The diameter of the wires shall not exceed 0,5 mm. Other types of temperature sensors may be used provided they can be shown to have the same accuracy or better and the same heat capacity or less.

<sup>2)</sup> The sensor may be located in the centre of the exit of the connector. During the beginning of the phases 1 and 3 condensate droplets may influence the temperature reading of the sensor. No actions shall be taken due to this misreading. As sensor a stainless steel sealed thermocouple of 1 mm diameter or less is advised. Other types of temperature sensor may be used provided they can be shown to have the same accuracy or better, the same heat capacity or less and the same corrosion resistance or better.

- the dew point of the ventilation air with an accuracy of 2 K or the relative humidity of the ventilation air with an accuracy of 5% abs.;
- the dew point of the combustion air with an accuracy of 2 K or the relative humidity of the combustion air with an accuracy of 5% abs. (might be the same sensor when the combustion air is taken from the same source as the ventilation air);
- the draught around the test assembly with an accuracy of 0,1 m/s (might be omitted if the test assembly is properly shielded from draught).

During the whole test period the following parameters shall be frequently measured and adjusted, to ensure that the values of the parameters stay as the tolerances given.

- the flue gas composition with respect to water, carbon dioxide, sulphur dioxide and chloride-content in the centre of the outlet of the combustor with an accuracy of 5 % of the nominal value (optional);
- the pressure in the test assembly (only in the case of positive pressure) with an accuracy of 5 % (once a week)<sup>1)</sup>.

The following parameters shall be measured only at the beginning of the test:

- the chlorine content of the fuel with an accuracy of 2 mg/m<sup>3</sup> for gas (might be omitted when certified declarations of the fuel distributor are available);
- the sulphur content of the fuel with an accuracy of 2,5 mg/m<sup>3</sup> for (V1) or an accuracy of 100 mg/m<sup>3</sup> for (V2) (might be omitted when certified declarations of the fuel distributor are available).

### A.1.5 Evaluation

After completion of the test sequence the metallic flue liner (including coatings and seals) shall undergo a visual inspection for obvious signs of corrosion and leakage. For a more detailed evaluation, the test assembly may need to be disassembled and cleaned.

One of the following procedures shall be used to determine whether perforation has occurred:

- put a small mirror near a suspected point of perforation and observe whether condensate forms on the mirror surface during the operation of the chimney (only applicable for positive pressure systems);
- measure the leakage of the chimney, preferably in situ using balloons at the top and bottom of the chimney for closure. The leakage should be less than twice the value allowed by the air tightness criteria (for newly installed chimneys);
- clean the chimney walls from corrosion products (using soft brushes and rinsing with water) and determine whether light spots are visible when a light bulb is positioned inside the chimney.

### A.1.6 Test report

The test report shall include the following information:

- a) name of applicant and/or manufacturer, order number, date;
- b) description of the test sample;
- c) description of the pipes and fittings covered by the corrosion test, based on the information of the manufacturer concerning material, surface quality, all manufacturing processes applied (maybe diameter dependent), short description of the manufacturing processes (tools, welding parameters etc.), special (surface) treatment;

---

<sup>1)</sup> Pressure readings can be disturbed by condensate droplets on the measurement points and tubes. Precautions should be taken (i.e. using drying agent) to avoid misinterpretation.

**EN 1856-1:2003 (E)**

d) test results

- 1) identification of test sample material,
- 2) values of pitting depth,
- 3) mean temperatures during the course of the test,
- 4) CO<sub>2</sub>-mean values of flue gas,
- 5) mean values of the condensate composition during the course of the test;

e) other observations;

f) summary of results and evaluation.

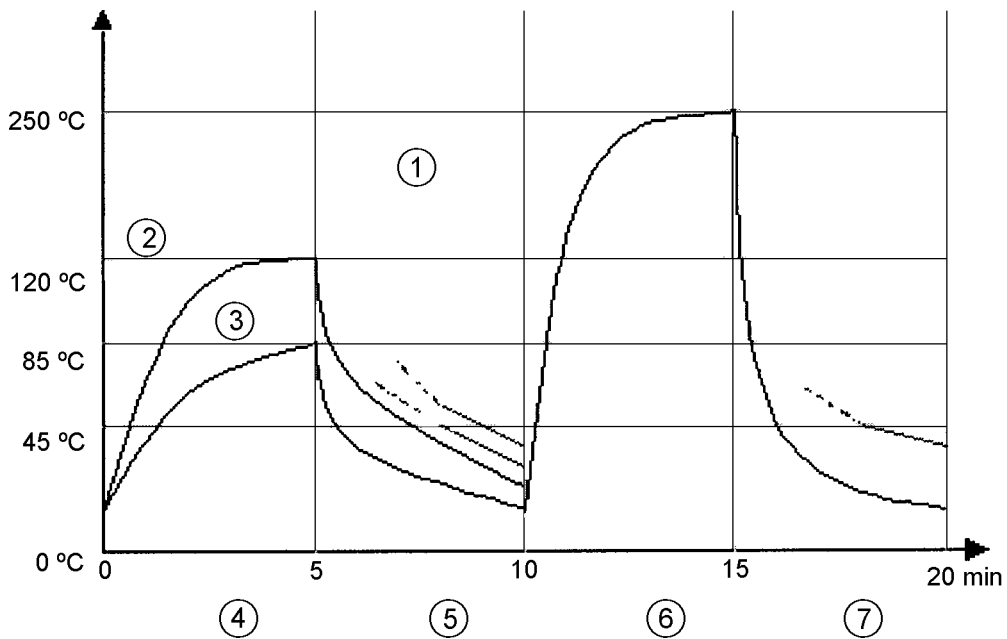

**Key**

1. Flue gas temperature  
Wall temperature
2. Dry
3. Wet
4. Phase 1  
Flue gas,  $T_{low}$
5. Phase 2  
Air
6. Phase 3  
Flue gas,  $T_{high}$
7. Phase 4  
Air

**Figure A.1 — Cycling sequence**

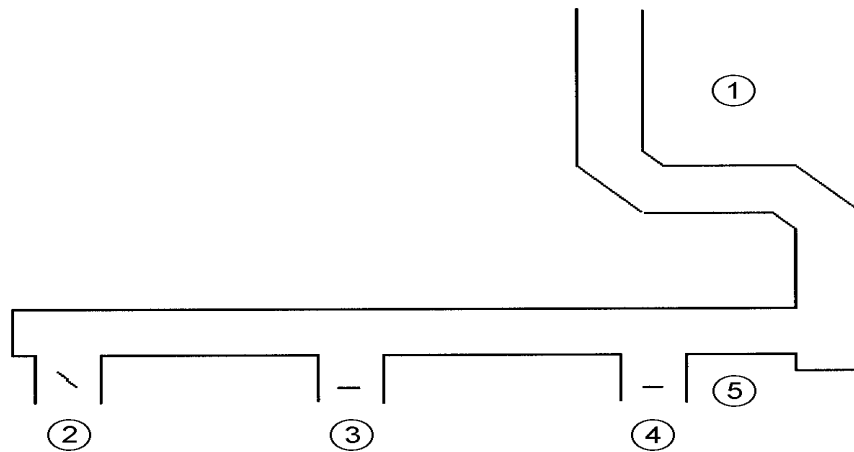

### Key

1. Test assembly
2.  $T_{high}$   
flue gas (combustor)
3.  $T_{low}$   
flue gas (combustor)
4.  $T_{amb}$   
air (fan)
5. Connector

Figure A.2 — Test assembly and connecting piece

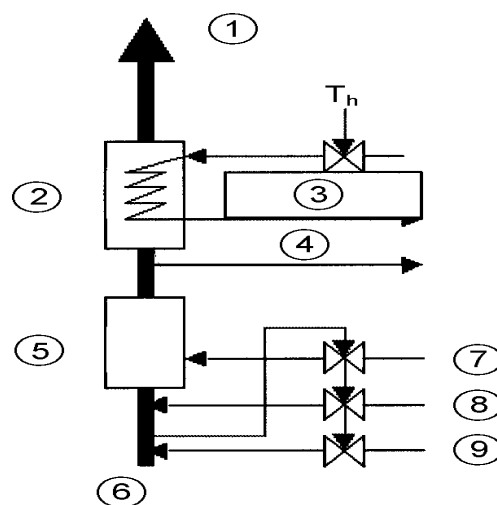

### Key

1. Flue gas
2. Cooler
3. Cooling water
4.  $CO_2$ ,  $H_2O$ ,  $SO_2$ ,  $Cl$   
Sample point
5. Combustor
6. Air
7. Fuel
8.  $SO_2$
9. Water

Figure A.3 — Flue gas generator

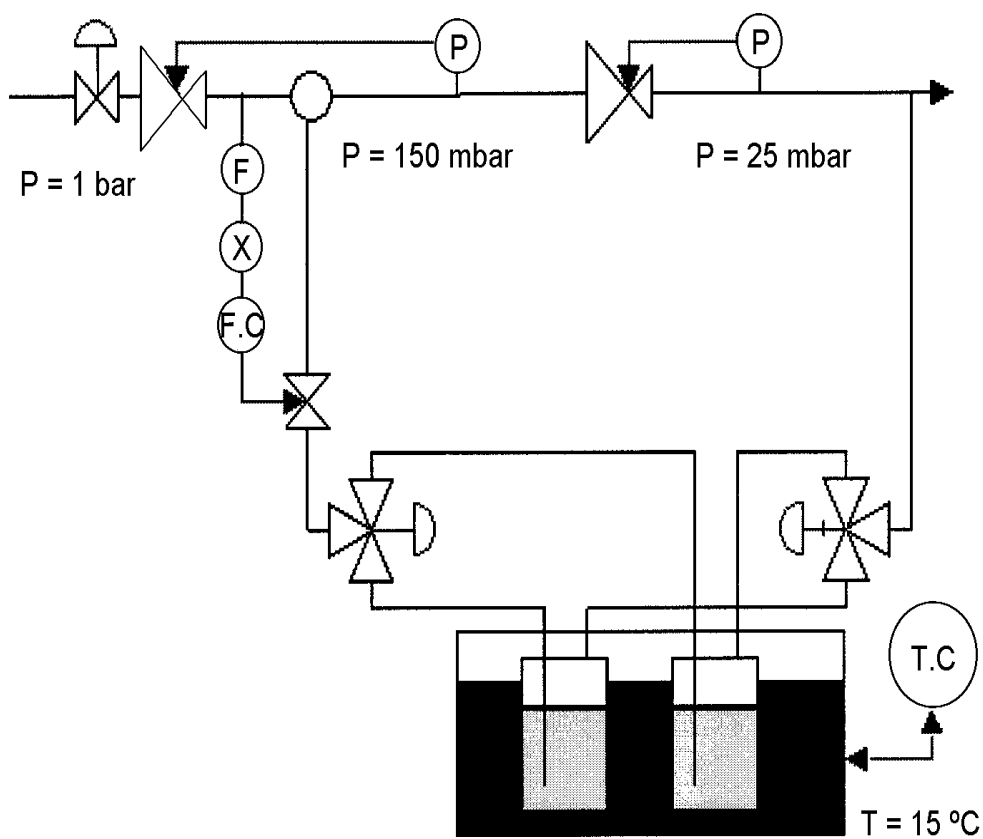

Figure A.4 — Spiking system (for one spiking fluid only)

## A.2 Corrosion test method for products designated V2

### A.2.1 General

This test protocol specifies the corrosion resistance test for the flue liners of both single- and multi-wall metal chimneys conveying products of combustion from appliance to outside atmosphere.

It specifies the test conditions for the chimney products designated V2.

### A.2.2 Pass/Fail criteria

When tested in accordance to the test method of A.2.4, the flue liner shall meet the following requirements.

#### A.2.2.1 Uniform corrosion

The decrease of the wall thickness, evaluated according to A.2.5.1, shall not exceed 1 %. This requirement shall not apply for stainless steel, because stainless steel is not sensitive against uniform corrosion.

#### A.2.2.2 Pitting corrosion

The maximum pitting depth, evaluated according to A.2.5.2, shall not exceed 20 %.

This requirement is shall not apply for materials which are more sensitive to uniform corrosion, e.g. aluminium.

#### A.2.2.3 Mean pitting corrosion

The mean value of the 10 points with the highest values for the pitting depth, evaluated according to A.2.5.3, shall not exceed 10%.

#### A.2.2.4 Intergranular corrosion

The maximum depth of zone attack by intergranular corrosion shall not exceed 20 %.

This requirement shall not apply for chimneys made of stainless steel, which are not preconditioned at temperatures of more than 400°C for this material is not sensitive for intergranular corrosion at low temperatures.

### A.2.3 Sampling

Unless otherwise stated the requirements of annex B shall apply.

### A.2.4 Test methods

#### A.2.4.1 Test assembly

The test assembly shall consist of one fitting with central condensate drain, one fitting with flue gas inlet (90°) and at least two rigid pipes. In the case of flexible pipes, the rigid pipes are replaced by the flexible pipe and fittings for the transition from rigid to flexible and from flexible to rigid (if any). The pipes and fittings shall be manufactured as intended for the series product. The overall length of the test sample shall be 2,5 m to 2,6 m, the diameter shall be 0,10 m to 0,13 m.

The pipes and fittings shall be stored in the original wrapping at normal room temperature and humidity not more than 60 % before the test

##### A.2.4.1.1 Preparation of test components

For single-wall chimneys the pipes and fittings shall be used as delivered by the manufacturer.

## EN 1856-1:2003 (E)

For multi-wall chimneys the pipes and fittings shall be disassembled to remove the outer casing. The test assembly shall be the liner with any metal connecting to the outer casing, which has been removed.

No other special pre-treatment shall be applied.

### A.2.4.2 Test room and test equipment

The test assembly shall be installed in a test rig that will heat or cool its entire outer surface.

A flue gas generator shall be fixed to the flue gas inlet of the test assembly using a non-metallic connecting flue pipe. The flue gas generator (i.e. a boiler) shall work with light oil and produce non-condensing flue gas.

NOTE A scheme of the test setup is shown in Figure A.5.

For monitoring the test procedure and evaluating the results devices shall be provided to measure the temperature of the flue gas, the wall of the sample and the test room (i.e. thermocouples as described in the test procedure), as follows:

- the velocity of the flue gas;
- the composition of the flue gas ( $\text{CO}_2$ , CO, Cl,  $\text{SO}_2$ );
- the weight and the composition of the condensate; and
- the depth of corrosion attack are needed.

During the test the temperature in the test room should be  $20\text{ °C} \pm 5\text{ °C}$ .

### A.2.4.3 Test procedure

#### A.2.4.3.1 Installation

The test assembly shall be installed in the test rig. At 0,3 m and 2,0 m above the flue gas inlet, thermocouples shall be fixed to the outside of the liner to measure the wall temperature.

Thermocouples shall be fixed at the inlet and the outlet of the test assembly to measure the flue gas temperature.

In the connecting flue pipe, just in front of the inlet to the test assembly, there shall be a sampling point for the flue gas composition.

A non-metallic hose and a non-metallic box shall be fixed to the condensate drain to gather the condensate out of the test assembly.

The room temperature is shall be measured 1 m above the flue gas inlet of the sample and at 1 m distance from the test rig.

#### A.2.4.3.2 Cycling condensate load

The flue gas generator shall produce a flue gas flow in such a way that the temperature at the inlet to the test assembly is  $60\text{ °C} \pm 3\text{ °C}$  and the flow rate is  $0,75\text{ m/s} \pm 0,25\text{ m/s}$ . The flue gas composition at the inlet shall meet the values of Table A.4.

**Table A.4 — Flue gas composition**

Fuel	Light oil
CO <sub>2</sub> content	$(12,5 \pm 0,5)\text{ vol. \%}$
SO <sub>2</sub> content	$(175 \pm 20) \times 10^{-6}\text{ g/g}$ (corresponds to 0,3 % S in the fuel)
Cl content	$2 \times 10^{-6}\text{ g/g}$ to $3 \times 10^{-6}\text{ g/g}$ (corresponds to $50 \times 10^{-6}\text{ g/g}$ of chlorine in the fuel)

The test assembly shall be exposed to 30 cycles, each cycle shall consist of a condensing flue gas phase of 8 h duration and a drying (evaporation) phase of at least 16 h duration.

The flue gas generator shall work at steady state conditions throughout the condensing phase of the cycle with the parameters described above. The wall of the sample shall be adjusted to  $40\text{ °C} + 3\text{ °C}$ .

In the drying phase, the flue gas generator shall be switched off and the wall of the sample is heated to a temperature of  $60\text{ °C} \pm 3\text{ °C}$ . There is no additional ventilation of the sample. The wall temperature shall be measured continuously.

The condensate for the whole test period is gathered in the box.

#### A.2.4.4 Controls

The flue gas temperature, the wall temperature and the room temperature shall be measured continuously.

The CO<sub>2</sub> and CO shall be measured once each phase. The Cl, SO<sub>2</sub> and velocity shall be measured once each test. This measurement shall be repeated if there is any change of the parameters of the flue gas generator (supplied fuel, power, etc.).

## EN 1856-1:2003 (E)

Monitoring of the flue gas temperature, the wall temperature and the CO<sub>2</sub> shall be carried out only at the beginning of the test.

### A.2.5 Evaluation

After the cycling condensate load the test assembly is shall be dismantled. The pipes and fittings shall be cut into two parts and visually examined regarding corrosion attack. Sites with corrosion attack shall be examined more intensively using a microscope. The depth of pitting shall be measured by analyzing sections through the cross section of the sample (metallographic examination).

To determine the maximum pitting depth, it is sufficient to analyze the pitting at the place with the maximum corrosion attack.

The weight of the condensate and the composition of the condensate shall be analyzed (Fe, Cr, Mo, Ni or other important alloy components of the sample).

#### A.2.5.1 Uniform corrosion

Based on the content of metallic components in the condensate, the weight of the condensate and the content of the components in the material of the sample as measured calculate the mass loss of material.

$$\Delta m = \frac{(m_{comp,cond} \cdot m_{cond})}{m_{comp,mat}}$$

where

$\Delta m$  mass loss of material, in g;

$m_{comp,cond}$  content of component in condensate, in g/kg condensate;

$m_{cond}$  weight of condensate, in kg;

$m_{comp,mat}$  content of component in material.

The mean decrease of wall thickness (absolute) is the result of the mass loss related to the density of the material and the inner surface of the vertical part of the sample. The relative decrease of the wall thickness for evaluation of the condensate resistance is calculated as the difference between the wall thickness before and after the test related to the minimum declared wall thickness.

#### A.2.5.2 Pitting corrosion

The depth of the pitting as measured according to A.2.2.2 is related to the minimum declared wall thickness.

#### A.2.5.3 Mean pitting corrosion

The mean value of the 10 points with the highest values for the pitting depth as measured according to A.2.2.3 is related to the minimum declared wall thickness. If there has been detected less than 10 points of corrosion attack the mean value shall be calculated by taking the sum of all measured values for the pitting depth and divide it by 10 (that means related to 10 points of corrosion attack).

#### A.2.5.4 Intergranular corrosion

If any point of intergranular corrosion is detected the maximum depth of attack shall be measured using the methods as described above. The value of the depth is related to the minimum declared wall thickness.

## A.2.6 Test report

The test report shall include the following information:

- a) name of applicant and/or manufacturer, order number, date;
- b) description of the test sample;
- c) description of the pipes and fittings covered by the corrosion test, based on the information of the manufacturer concerning material, surface quality, all manufacturing processes applied (maybe diameter dependent), short description of the manufacturing processes (tools, welding parameters, etc.), special (surface) treatment;
- d) test results
  - 1) identification of test sample material,
  - 2) values of pitting depth,
  - 3) mean temperatures during the course of the test,
  - 4) CO<sub>2</sub>-mean values of flue gas,
  - 5) mean values of the condensate composition during the course of the test;
- e) other observations;
- f) summary of results and evaluation.

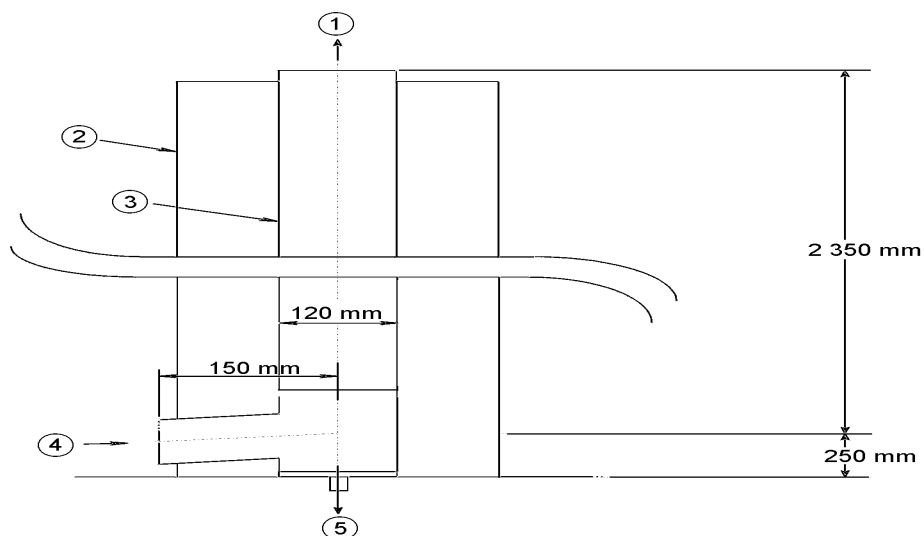

### Key

1. Flue gas outlet
2. Cooled/heated test rig
3. Test sample
4. Flue gas inlet
5. Condensate drain

Figure A.5 — Test arrangement

## A.3 Corrosion test method for products designated V3

### A.3.1 General

This test protocol specifies the corrosion resistance test for the flue liners of both single- and multi-wall metal chimneys conveying products of combustion from appliance to outside atmosphere.

It specifies the test conditions for the chimney products designated V3.

### A.3.2 Pass/Fail criteria

When tested in accordance to the test method of A.3.4, the flue liner shall meet the following requirements:

- there shall be no perforation of the wall;
- uniform loss of wall thickness shall not be greater than 5 %;
- local loss of wall thickness shall not be greater than 20 % of the minimum declared wall thickness;
- penetration depth of any crystalline corrosion shall not be greater than 20 % of the reference wall thickness.

### A.3.3 Sampling

Unless otherwise stated the requirements of annex B shall apply.

### A.3.4 Test methods

#### A.3.4.1 Test assembly

For the purpose of testing the corrosion resistance, a test assembly of approximately 4,5 m height and a flue diameter of 200 mm, shall be erected in accordance with the manufacturer's installation instructions, using those components with the lowest thermal resistance. The test assembly shall be connected alternately, to an appliance for coal with a heat output of 24 kW and an appliance for oil with a heat output of 29 kW, using insulated connecting components of the same diameter.

For the measurement of the flue gas- and wall-temperatures, thermocouples according to EN 1859:2000, annex E, paragraph 2), shall be installed; the flue gas temperatures shall be measured at the flue gas entry and at the chimney top, the wall temperatures shall be measured 2 m, 3 m and 4 m above the bottom and at the top of the chimney. Into the connecting flue pipe, tight closing shut off valves shall be installed, which are geared by two thermostats located at the chimney inlet. At a distance of approximately 2 × diameter behind the appliance control, openings for the measurement of the flue gas draught shall be located. Behind the flue gas collector at the top of the test chimney a flue gas exhauster shall be installed (see Figure A.6).

All physical values are specified as measured. All accuracy is specified as  $1\sigma$ .

#### A.3.4.2 Test procedure

The test chimney shall undergo the following procedure in the given sequence:

- 1 day exposure to the flue gases of the coal appliance;
- 1 day exposure to the flue gases of the oil appliance;
- thermal shock test (soot fire resistance);
- 1 day exposure to the flue gases of the coal appliance;
- 5 days exposure to the flue gases of the oil appliance.

The test chimney shall be operated under negative pressure at conditions near to practice. If necessary the exhaust fan shall be switched on to prevent the flue gases from the coal burning, entering the test room during the cooling phase. The appliance not in service shall be isolated by a shut-off valve. The following appliance operating conditions and the test conditions given in EN 1859:2000 subclause 4.5 shall apply.

**A.3.4.2.1 Flue gas generation-coal**

At the design heat output load of the coal burning appliance (24 kW) the flue gas conditions shall be as Table A.5.

**Table A.5 — Solid fuel appliance flue gas conditions**

CO <sub>2</sub>	13,8%
Flue gas mass flow	0,012 01 kg/s
Flue gas temperature	200°C
Under pressure	18 Pa

30 kg of anthracite as specified in Table A.6 shall be burnt in the coal appliance each day, typically during seven heating cycles.

**Table A.6 — Analysis of anthracite**

Size	3 cm to 5 cm
Density	740 kg/m <sup>3</sup> to 780 kg/m <sup>3</sup>
Max. CO <sub>2</sub>	19,3%
Carbon	85%
Hydrogen	3%
Oxygen	2%
Nitrogen	1%
Sulfur	1%
H <sub>2</sub> O	3%
Ash	5%
Calorific value	31 400 kJ/kg

Each heating cycle shall be governed by the two thermostats. The first thermostat, with the help of an electrically powered servo motor, shall close the supply of combustion air when the temperature of 300°C is reached, the second thermostat shall open the combustion air supply again, when the temperature of the flue gas has dropped below 90°C (see Figures A.6 and A.7).

**A.3.4.2.1.1 Spiking-coal**

For the purpose of enhancing the corrosiveness of the flue gas and therefore reducing the necessary test duration, daily amounts of chlorine (as sodium chloride) and sulphur (as sulphur dioxide) shall be added as if (in one week of normal service) 100 kg of coal with a chlorine content of 0,05 % and a sulphur content of 0,75 % would be burnt. Sodium chloride to the coal, sulphur dioxide shall be added to the combustion air. For an additional acceleration, 30 g of polyvinyl chloride (PVC) shall be added each day.

**A.3.4.2.1.2 Flue gas generation-oil**

At the design heat output load of the oil burning appliance (29 kW) the flue gas conditions shall be as Table A.7.

**Table A.7 — Oil appliance flue gas conditions**

CO <sub>2</sub> content	13%
Flue gas mass flow	0,012 01 kg/s
Flue gas temperature	190°C (nominal)
Under pressure	9 Pa

The heating appliance for light oil shall be operated in such a way that the first thermostat shuts off the oil burner, when the temperature of 200°C is reached and the second thermostat starts the oil burner again, when the temperature of the flue gas has dropped below 90°C, and approximately 15 cycles are realised. The oil-flow is 3,7 l/h.

**A.3.4.2.1.3 Spiking-oil**

To enhance the corrosiveness of the flue gas and therefore reducing the necessary test duration, an amount of sulphur dioxide shall be added to the combustion air as if the light oil would have a sulphur content of 2 %.

**A.3.4.2.2 Thermal shock**

During the thermal shock test (according to EN 1859:2000, subclause 4.5.3.2) the hot flue gas shall be introduced into the test chimney through the inspection opening, which is under the T-piece. The flue gas injection shall be stopped in the case of ignition and burning of deposited soot until the flue gas temperature at the top of the test chimney has dropped below 900°C. Testing of gas tightness according to EN 1859 is not required.

**A.3.4.3 Ambient conditions**

A supply of clean outdoor air for combustion shall be provided. Care shall be taken to avoid contamination from refrigerant gases, chlorine, cleaning solvents, welding fumes, etc. (e.g. by filtering the air).

The test room temperature shall be 20 °C ± 5 °C.

In a circle of 2 m around the test assembly the maximum draught shall be below 0,5 m/s. These conditions shall be fulfilled for at least 90 % of the test period<sup>1)</sup>.

**A.3.4.4 Controls**

The following shall be measured at the beginning of the test:

- the chlorine content of the fuel with an accuracy of 2 mg/m<sup>3</sup>;
- the sulphur content of the fuel with an accuracy of 100 mg/m<sup>3</sup>.

At the start and finish of each 5 days exposure, record and adjust when necessary

- the fuel input rate with an accuracy ± 5 %.

During the whole test period the following parameters shall to be recorded:

---

<sup>1)</sup> This condition is assumed to be fulfilled without draught measurement if appropriate tight screening is placed around the test assembly. The distance from the test assembly to the screening must so large that the temperature of the screening is less than 2 K above test room temperature, but not more than 1 m.

## EN 1856-1:2003 (E)

- the inner wall temperature at the end of the test assembly (50 cm below the outlet) with an accuracy of 5 K<sup>1)</sup>;
- the temperature of the flue gas at the measuring points described in subclause 7.1 with an accuracy of 10 K<sup>2)</sup>;
- the number of test cycles;
- the test room temperature near the test assembly with an accuracy of 1 K;
- the dew point of the combustion air with an accuracy of 2 K or the relative humidity of the combustion air with an accuracy of 5 % abs.;
- The draught around the test assembly with an accuracy of 0,1 m/s. This can be omitted if it has been demonstrated that the test assembly is properly shielded from draught.

### A.3.5 Evaluation

On completion of the test sequence, the metallic flue liner (including coatings and seals) shall undergo a visual inspection for obvious signs of corrosion and leakage. The deposits on the inside surface at the flue gas entry and at the top shall be chemically analysed. For a more detailed evaluation the test assembly shall be dismantled and cleaned.

Six pieces of at least 50 mm length shall be cut out from observed corroded areas; these test pieces shall be investigated, using metallographic sectioning and/or a microscopic focussing technique, to determine the maximum depth of any detected pits. On further test specimens the stability against inter-crystalline corrosion shall be tested according to EN ISO 3651-2.

### A.3.6 Test report

The test report shall include the following information:

- a) name of applicant and/or manufacturer, order number, date;
- b) description of the test sample ;
- c) description of the pipes and fittings covered by the corrosion test, based on the information of the manufacturer concerning material, surface quality, all manufacturing processes applied (maybe diameter dependent), short description of the manufacturing processes (tools, welding parameters, etc.), special (surface) treatment;
- d) test results
  - 1) identification of test sample material,
  - 2) values of pitting depth;
- e) other observations;
- f) summary of results and evaluation.

---

<sup>1)</sup> For the temperature measurements NiCr-Ni thermocouples may be used. The diameter of the wires shall not exceed 0.5 mm. Other types of temperature sensor may be used provided they can be shown to have the same accuracy or better and the same heat capacity or less.

<sup>2)</sup> The sensor may be located in the centre of the exit of the connector. During the beginning of the phases 1 and 3 condensate droplets may influence the temperature reading of the sensor. No actions must be taken due to these misreadings. As sensor a stainless steel sealed thermocouple of 1 mm diameter or less is advised. Other types of temperature sensor may be used provided they can be shown to have the same accuracy or better, the same heat capacity or less and the same corrosion resistance or better.

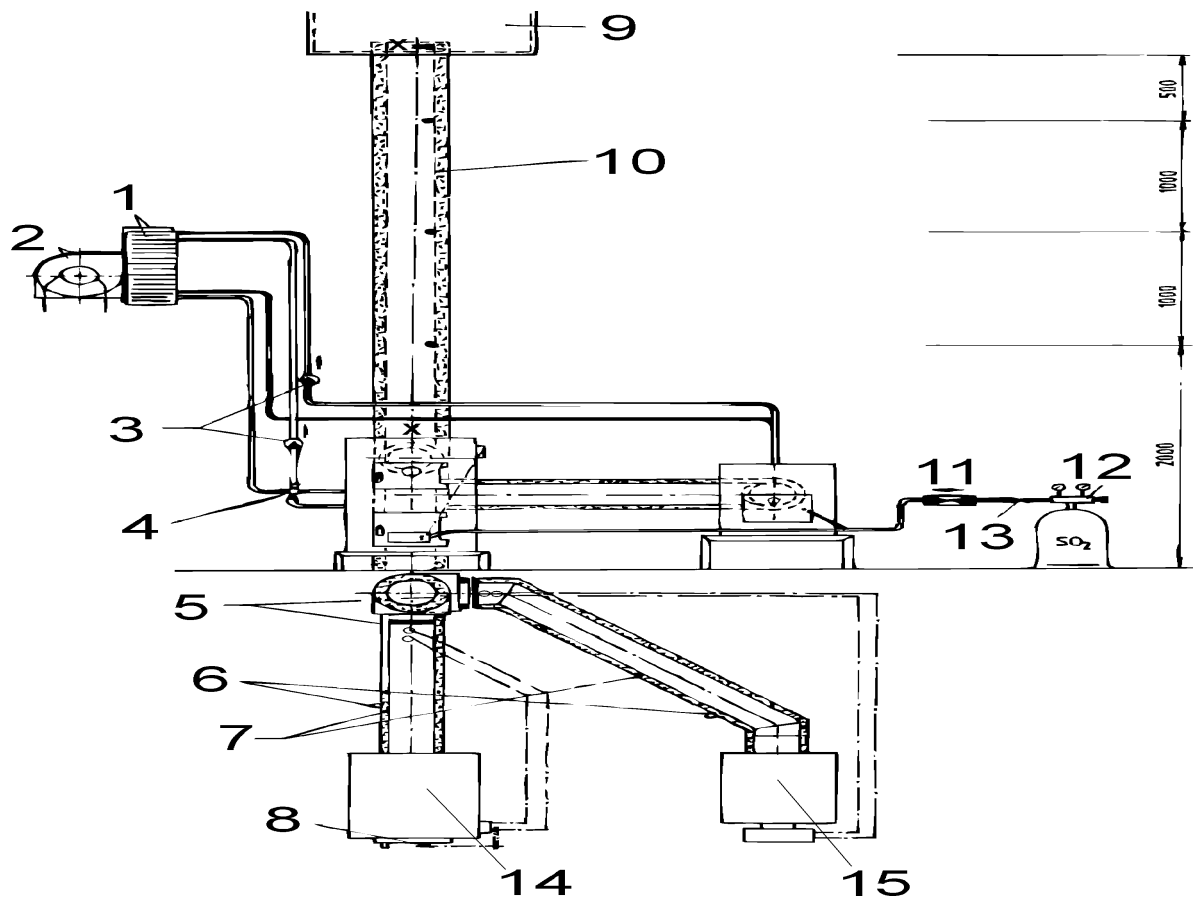

**Key**

- |   |                       |    |                            |    |                              |
|---|-----------------------|----|----------------------------|----|------------------------------|
| 1 | Heat exchanger        | 6  | Control opening            | 11 | Flow meter                   |
| 2 | Ventilator            | 7  | Insulated connection pipes | 12 | Pressure reducer             |
| 3 | Pump                  | 8  | Air entry regulation       | 13 | Magnet valve                 |
| 4 | Four way-mixing valve | 9  | Flue gas exhauster         | 14 | Appliance for solid fuel     |
| 5 | Closing device        | 10 | Test chimney               | 15 | Appliance for light oil fuel |
- 
- X Thermo-elements for the flue gas temperature
  - Thermostat for cycle control
  - Thermo-elements for flue liner temperature

**Figure A.6 — Test assembly**

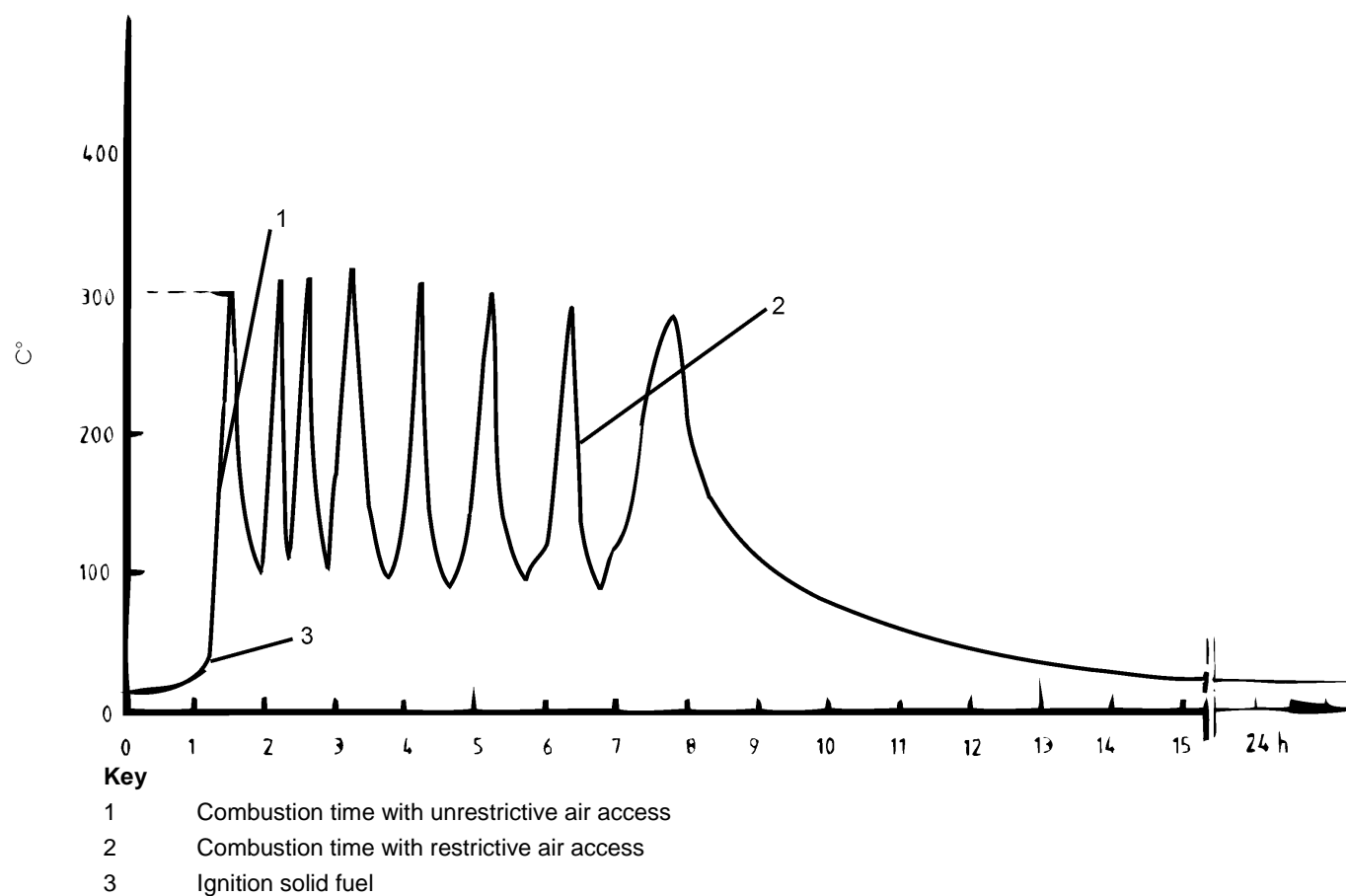

Figure A.7 — Heating cycles solid fuel appliance. Function diagram

## Annex B (normative)

### Choice of size for type test and sampling

**B.1** Thermal testing shall be undertaken on the largest diameter up to and including 200 mm. All diameters within a range of products of the same design and designation shall be deemed to meet the requirements met by the tested samples.

**B.2** Structural/wind loading shall be undertaken on the smallest, largest and one diameter in between. In some cases, this may depend on the manufacturer instructions (e.g. same bracket spacing for different diameters)

**B.3** Gas tightness, see thermal testing (as gas tightness is tested before and after thermal performance).

An additional gas tightness test for positive pressure shall be done on at least two chimney sections and a joint, of all diameters not subjected to thermal testing.

**B.4** Rainwater penetration for sizing see thermal testing.

**B.5** Water vapour shall be performed only on nominal size 150 mm or nearest.

**B.6** Resistance to condensate (see thermal testing).

**B.7** Terminals, this is geometry/diameter related and may need to be done on the largest size.

**B.8** Samples, the number of components to be supplied is determined by the units required for each applicable test (see EN 1859).

**B.9** The factory production control system shall verify that normal production units are identical to the samples used for type testing.

**B.10** Nature of changes requiring further type test.

- a) material or method of construction changes;
- b) changes which affect designation parameters as appropriate.

## **Annex C** (normative)

### **Sampling for factory production control**

#### **C.1 Sampling plans**

Sampling plans shall be selected from the tables published in ISO 2859-1.

##### **C.1.1 Acceptable quality level (AQL)**

The AQL shall be decided in relation to the nature of the inspection feature being controlled. For defects classed as MAJOR, the sampling plan shall be based on an AQL of 4,0.

NOTE Classification of defects should be the responsibility of the person responsible for the manufacturing process.

##### **C.1.2 The inspection level**

The inspection level defines the relationship between the batch size and the sample size, all incoming goods shall be subjected to inspection level II.

##### **C.1.3 Normal, tightened or reduced inspection**

Normal inspection shall be used initially on all incoming materials, after which, the following rules apply:

- a) when ten successive batches have been accepted on original there can be a switch to reduced inspection. This shall remain in operation until one batch is rejected, at which point revert back to normal inspection;
- b) when two out of any five successive batches have been rejected on original inspection, there can be a switch to tightened inspection. This shall remain in operation until five successive batches have been accepted, at which point revert back to normal inspection.

### C.1.4 Single, double, multiple or sequential sampling

Unless otherwise specified, all incoming material shall be subjected to single sampling plans.

### C.1.5 Batch quantity

Once the first four variables have been decided, the sampling plan tables shall indicate the amount of samples to be inspected for any given batch quantity.

All information regarding levels of inspection shall be indicated where appropriate on the inspection records.

## C.2 Inspection levels and procedures

### C.2.1 Incoming material

Sample inspected to ISO 2859-1 using an AQL = 2,5, general inspection level II, single sampling plan for normal inspection incorporating the switching rules to tightened or reduced inspection if necessary. All mill certification shall be checked against the relevant technical specification.

### C.2.2 In-process inspection

#### C.2.2.1 All dimensional aspects

An inspection feature ~~is~~ shall be introduced each time the material changes form during the process.

A first inspection ~~is~~ shall be implemented and verified by either the setter or supervisor at each machine operation and from then on the operators will carry out each required dimensional check at a rate of four per batch - unrecorded, using go-no go gauges.

This is supplemented by a beginning and end of shift full dimensional check by the line supervisor using measuring equipment. This is a record check, a register of all results being maintained.

#### C.2.2.2 Joint leakage tests

- a) Insulated product, test rate = 1 per batch:
- b) Uninsulated product

Straight lengths test rate = 1 per week,

Adjustable elbows test rate = 1 per day.

#### C.2.2.3 Insulation weight checks

Where appropriate 100 % inspection, each insulated product shall be weighed after filling to ensure correct in-pipe density has been achieved. Four results per batch shall be recorded.

### C.2.3 Volume and density checks

Over each 12 months period, volume and density checks shall be conducted on all insulated products of all length and diameter sizes. This shall be carried out to a formalised programme to ensure that a quantity of product is tested each month.

### C.2.4 Finished goods checks

- a) At the end of the manufacturing process, prior to packaging, each unit shall be visually inspected for damage. When boxed, the carton shall be stamped with the date of manufacture.

**EN 1856-1:2003 (E)**

- b) At the warehouse, once a week, the goods inwards inspector shall randomly select four samples from a particular product range, and subject each item to full dimensional checks including joint leakage test and weight checks. This shall be also carried out to a formalised programme.

## Annex D (normative)

### Factory production control

The following components and the criteria shall be included in the factory production control scheme.

#### D.1 Insulation material

- a) Specification of insulation material.
- b) Density value - for thermal conductivity and factory production control purposes.

Supplier's declaration for material type and properties shall be accepted, provided that the supplier has an appropriate quality assurance system.

#### D.2 Metals, including coatings

- a) Type, composition.
- b) Thickness.
- c) Finish.

Supplier's declaration for material type and properties shall be accepted, provided that the supplier has an appropriate quality assurance system.

#### D.3 Supports

- a) Material type.
- b) Structural section.
- c) Additional components, nuts, bolts, fixings.

Supplier's declaration for material type and properties shall be accepted, provided that the supplier has an appropriate quality assurance system.

#### D.4 Seals and sealants

- a) Type, including identification or composition, when the conformity certificate is not available.
- b) Dimensions.

Supplier's declaration for material type and properties shall be accepted, provided that the supplier has an appropriate quality assurance system.

#### D.5 Manufacturing checks

##### D.5.1 Dimensions

Dimensions of critical parts shall be confirmed during the manufacturing and/or on completion:

- a) material thickness;
- b) diameter, may be checked through the sheet size during manufacture;

## **EN 1856-1:2003 (E)**

- c) length;
- d) coupler characteristic (e.g. joint fit).

### **D.5.2 Other checks**

These checks shall be carried out during the manufacturing process:

- a) leakage (negative and, if appropriate, positive pressure). This test should be performed on at least two chimney sections with a complete joint, including sealants;
- b) mass;
- c) density.

## Annex ZA (informative)

### Clauses of this European standard addressing the provisions of the EU Construction Products Directive

#### ZA.1 Scope and relevant characteristics

This European standard has been prepared under a mandate M/105 “Chimneys, flues and specific products” given to CEN by the European Commission and the European Free Trade Association.

The clauses of this European standard shown in this annex meet the requirements of the mandate given under the EU Construction Products Directive (89/106/EEC).

Compliance with these clauses confers a presumption of fitness of the metal system chimney products covered by this annex for the intended uses indicated herein; reference shall be made to the information accompanying the CE marking.

**WARNING:** Other requirements and other EU Directives, not affecting the fitness for intended uses, can be applicable to the metal system chimney products falling within the scope of this European Standard.

**NOTE** In addition to any specific clauses relating to dangerous substances contained in this standard, there may be other requirements applicable to the products falling within its scope (e.g. transposed European legislation and national laws, regulations and administrative provisions). In order to meet the provisions of the EU Construction Products Directive, these requirements need also to be complied with, when and where they apply. *NOTE An informative database of European and national provisions on dangerous substances is available at the Construction web site on EUROPA (CREATE, accessed through <http://europa.eu.int>).*

**EN 1856-1:2003 (E)**

This annex establishes the conditions for the CE marking of the metal system chimney products intended for the uses indicated in Tables ZA.1 and ZA.2 and shows the relevant clauses applicable:

The scope of this annex is defined by Tables ZA.1 and Table ZA.2.

**Table ZA.1 — Scope and relevant requirement clauses**

<b>Product: metal system chimney products as covered in clause 1 of this standard, except terminals and supports.</b>			
<b>Intended use: single- and multi-wall chimneys</b>			
<b>Essential Characteristics</b>	<b>Requirement clauses in this European Standard(s)</b>	<b>Levels and/or classes</b>	<b>Notes</b>
Compressive strength	6.1.1.1 Chimney sections and fittings	None	Pass/fail criteria Manufacturer's declared value
Resistance to fire	6.2 Resistance to fire	G (xx)	Declared class and distance to adjacent combustible material xx, in mm.
Gas tightness /leakage	6.3.1 Gas tightness	None	Pressure class (this reflects a gas tightness determined by a threshold leakage rate appropriate to the pressure class)
Flow resistance	6.4.7.1 Flow resistance of chimney sections. 6.4.7.2 Flow resistance of chimney fittings.	None	Mean value of roughness, in mm. Coefficient of flow resistance.
Thermal resistance	6.4.3 Thermal resistance	None	Declared value, in m <sup>2</sup> K/W.
Thermal shock resistance	6.3 Gas tightness 5.2 Declared internal diameter	None	Pass fail criteria. Maintenance of gas tightness and maintenance of declared internal diameter.
Flexural tensile strength	6.1.2 Tensile strength (only for means of connection for chimney sections and fittings) 6.1.3.1 Non vertical installation 6.1.3.2 Components subject to wind load	None	Pass fail criteria. Manufacturer's declared value Pass fail criteria. Manufacturer's declared value Pass fail criteria. Manufacturer's declared value
Durability against chemicals	6.4.4 Water and vapour diffusion resistance 6.4.5 Condensate penetration resistance	None	Pass-fail criteria Pass-fail criteria

Durability against corrosion	6.5.1 Durability against corrosion	None	Either declared material and thickness or pass-fail criteria (based on a corrosion test).
Freeze thaw	6.5.3 Freeze thaw resistance	None	Product declaration for metal lined chimney products

The requirement on a certain characteristic is not applicable in those Member States (MSs) where there are no regulatory requirements on that characteristic for the intended use of the product. In this case, manufacturers placing their products on the market of these MSs are not obliged to determine nor declare the performance of their products with regard to this characteristic and the option "No performance determined" (NPD) in the information accompanying the CE marking (see clause ZA.3) may be used. The NPD option may not be used, however, where the characteristic is subject to a threshold level.

**Table ZA.2 — Scope and relevant requirement clauses**

<b>Product: terminals as covered in clause 1 of this standard</b>			
<b>Intended use: single- and multi-wall chimneys</b>			
<b>Essential Characteristics</b>	<b>Requirement clauses in this European Standard(s)</b>	<b>Levels and/or classes</b>	<b>Notes</b>
Flow resistance	6.4.7.3 Flow resistance of terminals	None	Coefficient of flow resistance.

The requirement on a certain characteristic is not applicable in those Member States (MSs) where there are no regulatory requirements on that characteristic for the intended use of the product. In this case, manufacturers placing their products on the market of these MSs are not obliged to determine nor declare the performance of their products with regard to this characteristic and the option "No performance determined" (NPD) in the information accompanying the CE marking (see clause ZA.3) may be used. The NPD option may not be used, however, where the characteristic is subject to a threshold level.

## **ZA.2 Procedure(s) for attestation of conformity of [construction products]**

### **ZA.2.1 System(s) of attestation of conformity**

The system(s) of attestation of conformity of [the construction products] indicated in Tables ZA.1 and ZA.2 in accordance with the Decision of the Commission 95/467/EC of 27-09-95 as given in Annex III of the mandate for "Chimneys, flues and specific products", is shown in Table ZA.3 for the indicated intended use(s) and relevant level(s) or class(es).

**Table ZA.3 — System(s) of attestation of conformity**

Product(s)	Intended use(s)	Level(s) or class(es)	Attestation of conformity system(s)
Metal system chimney products	Chimneys	Any	2+
Terminals			4
<p>System 2+: See Directive 89/106/EEC (CPD) Annex III.2.(ii), First possibility, including certification of the factory production control by an approved body on the basis of initial inspection of factory and of factory production control as well as of continuous surveillance, assessment and approval of factory production control.</p> <p>System 4: See Directive 89/106/EEC (CPD) Annex III.2.(ii), Third possibility</p>			

The attestation of conformity of the [construction products] in Tables ZA.1 and ZA.1.2 shall be based on the evaluation of conformity procedures indicated in Tables ZA.4 and ZA.5 respectively resulting from application of the clauses of this or other European Standard indicated therein.

**Table ZA.4 — Assignment of evaluation of conformity tasks for metal system chimney products in Table ZA.1**

Tasks		Content of the task	Evaluation of conformity clauses to apply
Tasks for the manufacturer	Factory production control (F.P.C)	Parameters related to all relevant characteristics of Table ZA.1	10.3
	Initial type testing	All relevant characteristics of Table ZA.1	10.2
Tasks for the notified body	Certification of F.P.C on the basis of ...	... initial inspection of factory and of F.P.C	10.3
		... continuous surveillance, assessment and approval of F.P.C. <i>Compressive strength</i> <i>Resistance to wind load</i> (for kits of free standing and attached chimneys)	10.3

Table ZA.5 — Assignment of evaluation of conformity tasks for terminals in Table ZA.2

Tasks		Content of the task	Evaluation of conformity clauses to apply
Tasks for the manufacturer	Factory production control (F.P.C)	Parameters related to all relevant characteristics of Table ZA.2	10.3
	Initial type testing	All relevant characteristics of Table ZA.2	10.2

### ZA.2.2 EC Declaration of conformity

*(In case of products under system 2+):* When compliance with the conditions of this Annex is achieved, and once the notified body has drawn up the certificate mentioned below, the manufacturer or his agent established in the EEA shall prepare and retain a declaration of conformity, which entitles the manufacturer to affix the CE marking. This declaration shall include:

- name and address of the manufacturer, or his authorised representative established in the EEA, and the place of production;
- description of the product (type, identification, use, etc.), and a copy of the information accompanying the CE marking;
- provisions to which the product conforms (e.g. annex ZA of this standard);
- particular conditions applicable to the use of the product (e.g. provisions for use under certain conditions, etc.);
- the number of the accompanying factory production control certificate;
- name of, and position held by, the person empowered to sign the declaration on behalf of the manufacturer or his authorised representative.

The declaration shall be accompanied by a factory production control certificate, drawn up by the notified body, which shall contain, in addition to the information above, the following:

- name and address of the notified body;
- conditions and period of validity of the certificate, where applicable;
- name of, and position held by, the person empowered to sign the certificate.

*(In case of products under system 4):* When compliance with this Annex is achieved, the manufacturer or his agent established in the EEA shall prepare and retain a declaration of conformity (EC Declaration of conformity), which entitles the manufacturer to affix the CE marking. This declaration shall include:

- name and address of the manufacturer, or his authorised representative established in the EEA, and place of production;
- description of the product (type, identification, use, etc.), and a copy of the information accompanying the CE marking;
- provisions to which the product conforms (e.g. annex ZA of this standard);
- particular conditions applicable to the use of the product (e.g. provisions for use under certain conditions, etc.);

## EN 1856-1:2003 (E)

- name of, and position held by, the person empowered to sign the declaration on behalf of the manufacturer or of his authorised representative.

The above mentioned declarations shall be presented in the official language or languages of the Member State in which the product is to be used.

### ZA.3 CE marking and labelling

The manufacturer or his authorised representative established within the EEA is responsible for the affixing of the CE marking. The CE marking symbol to affix shall be in accordance with Directive 93/68/EC and shall be shown, together with the identification number of the notified body (where relevant), the name or identifying mark of the manufacturer, the number of the relevant standard and the relevant designation on the product or the packaging. Additionally, the CE marking symbol and all the elements listed below shall be on the accompanying documents (e.g. a delivery note). The following information shall accompany the CE marking symbol:

- identification number of the certification body (only for products under systems 1+, 1 and 2+);
- name or identifying mark and registered address of the manufacturer;
- the last two digits of the year in which the marking is affixed;
- number of the EC Certificate of conformity or factory production control certificate (if relevant);
- reference to this European Standard;
- description of the product: generic name, material, dimensions, etc. and intended use;
- information on the relevant essential characteristics listed in Tables ZA.1 and ZA.2 presented as:
  - a) declared values and, where relevant, level or class to declare for each essential characteristic as indicated in "Notes" in Tables ZA.1 and ZA.2;
  - b) as an alternative, standard designation(s) alone in accordance with clause 9 or in combination with declared values as above; and
  - c) "no performance determined" for characteristics where this is relevant.

The “no performance determined” (NPD) option may not be used where the characteristic is subject to a threshold level. Otherwise, the NPD option may be used when and where the characteristic, for a given intended use, is not subject to regulatory requirements in the Member State of destination.

Figures ZA.1, ZA.2, ZA.3 and ZA.4 give examples of the information to be given on the product, packaging and/or commercial documents.

**Figure ZA.1 — Example of CE marking on the product or on the packaging**

Example for a chimney section



 01234	<p><i>CE conformity marking, consisting of the “CE”-symbol given in directive 93/68/EEC.</i></p> <p><i>Identification number of the notified body (where relevant)</i></p>
<b>AnyCo Ltd, PO Box 21, B-1050</b>	<p><i>Name or identifying mark and registered address of the manufacturer</i></p>
<b>EN 1856-1</b>  <b>T400 - N2 - D - Vm - G 50 – L50045</b>	<p><i>Number of European Standard</i></p> <p><i>Appropriate designation according to clause 9</i></p>

Figure ZA.2 — Example of CE marking information on the accompanying documents

Example for a chimney section

 01234
<b>AnyCo Ltd, PO Box 21, B-1050</b>  01  <b>01234-CPD-00234</b>
<b>EN 1856-1</b>  Metal system chimney section  Multi-wall  <b>T400 - N2 – D - Vm - L50045- G 50</b>  <b>Compressive strength</b>  Maximum load: 30 m of chimney sections  <b>Flow resistance</b>  Mean value of roughness: 0,1 mm  <b>Thermal resistance</b>  0,22 w/m²K at designation temperature  <b>Thermal shock resistance: Yes</b>  <b>Flexural strength</b>  Tensile strength: 2 m  Non-vertical installations: Maximum offset between supports: 3 m at 45°  Wind load: Free standing height: 1,5 m above last support  Maximum spacing of lateral supports: 3 m  <b>Freeze thaw resistance: Yes</b>

*CE conformity marking, consisting of the “CE”-symbol given in directive 93/68/EEC.*

*Identification number of the notified body*

*Name or identifying mark and registered address of the manufacturer*

*Last two digits of the year in which the marking was affixed*

*Certificate number*

*Number of European Standard*

*Definition of the product*

*And appropriate designation according to clause 9*

*Information on mandated characteristics not included in the designation or threshold values to be given (see Table ZA.1)*

In addition to any specific information relating to dangerous substances shown above, the product should also be accompanied, when and where required and in the appropriate form, by documentation listing any other legislation on dangerous substances for which compliance is claimed, together with any information required by that legislation.

NOTE European legislation without national derogations need not be mentioned.

Figure ZA.3 — Example for a chimney fitting. T-piece in the accompanying documents

 01234	<i>CE conformity marking, consisting of the "CE"-symbol given in directive 93/68/EEC.</i>  <i>Identification number of the notified body</i>
<b>AnyCo Ltd, PO Box 21, B-1050</b>  00  <b>01234-CPD-00234</b>	<i>Name or identifying mark and registered address of the manufacturer</i>  <i>Last two digits of the year in which the marking was affixed</i>  <i>Certificate number</i>
<b>EN 1856-1</b>  Metal system chimney fitting  Single-wall T piece  <b>T250 – P1 - W – V2 - L60060 - O 50</b>  <b>Compressive strength</b>  Maximum load: 30 m of chimney sections  <b>Flow resistance</b>  Coefficient of friction: 0,3 for 90° change of direction  <b>Thermal resistance</b>  0,22 w/m <sup>2</sup> K at designation temperature  <b>Thermal shock resistance:</b> NPD  <b>Flexural strength</b>  Tensile strength: 2 m  Non-vertical installations: NPD  Wind load: Free standing height: NPD  <b>Freeze thaw resistance:</b> Yes	<i>Number of European Standard</i>  <i>Definition of the product</i>  <i>And appropriate designation according to clause 9</i>  <i>Information on mandated characteristics not included in the designation or threshold values to be given (see Table ZA.1)</i>

In addition to any specific information relating to dangerous substances shown above, the product should also be accompanied, when and where required and in the appropriate form, by documentation listing any other legislation on dangerous substances for which compliance is claimed, together with any information required by that legislation.

NOTE European legislation without national derogation need not be mentioned.

Figure ZA.4 — Example for a chimney fitting. Terminal in the accompanying documents

	<p><i>CE conformity marking, consisting of the “CE”-symbol given in directive 93/68/EEC.</i></p>
<p><b>AnyCo Ltd, PO Box 21, B-1050</b></p>	<p><i>Name or identifying mark and registered address of the manufacturer</i></p>
<p><b>00</b></p>	<p><i>Last two digits of the year in which the marking was affixed</i></p>
<p><b>EN 1856-1</b></p>	<p><i>No. of European Standard</i></p>
<p>Metal system chimney fitting Terminal</p>	<p><i>Definition of the product and appropriate designation according to clause 9</i></p>
<p><b>Flow resistance</b> Coefficient of friction: 0.5</p>	<p><i>Information on mandated characteristics not included in the designation or threshold values to be given (see Table ZA.2)</i></p>

In addition to any specific information relating to dangerous substances shown above, the product should also be accompanied, when and where required and in the appropriate form, by documentation listing any other legislation on dangerous substances for which compliance is claimed, together with any information required by that legislation.

NOTE European legislation without national derogations need not be mentioned.

## Bibliography

- EN 563                      *Safety of machinery - Temperatures of touchable surfaces - Ergonomics data to establish temperature limit values for hot surfaces.*
- prEN 1856-2:2000        *Chimneys - Requirements for metal chimneys - Part 2: Metal liners and connecting flue pipes*
- ISO 8044                   *Corrosion of metals and alloys - Basic terms and definitions.*
- EN ISO 9001:2000        *Quality management systems - Requirements (ISO 9001:2000).*